



---

**W575H-W5300H Compass**

Washer extractor

Tvättmaskin

---



## List of issues

### **W575H Compass, W5105H Compass, W5130H Compass, W5180H Compass, W5240H Compass, W5300H C**

Illustration	Page	Table of contents
500199	99	Electronic coin meter
500201	101	Coin meter
500231	55	CPU
500280	25	Lining and top panel
500281	35	Drum, rear gable
500282	39	Door and hinged joint
500284	45	Motor
500285	47	Motor control unit
500286	61	Electric components connection
500287	63	Drain valve and hoses
500288	65	Water connections
500289	67	Inlet valves and cable set
500290	69	Inlet valves and cable set
500291	71	Inlet valves and cable set
500292	73	Inlet valves and cable set
500293	79	Drain valve
500294	81	Drain valve, electrical
500295	83	Drain pump
500296	85	Steam components
500297	87	Detergent container
500298	7	Base and outer drum
500299	9	Base and outer drum
500300	11	Base and outer drum
500301	29	Lining and top panel
500302	75	Inlet valves and cable set
500303	77	Inlet valves and cable set
500304	89	Out of balance switch
500305	15	Base and outer drum
500306	19	Base and outer drum
500307	23	Base and outer drum
500315	91	Emergency stop
500316	93	Key switch
500323	57	Program selector
500361	49	Power balance unit
500371	51	Control panel
500372	53	Control panel
500446	103	Coin meter (for coinbox height 90mm)
500452	95	Coinbox housing (for coinbox height 70mm)
500453	97	Coinbox housing (for coinbox height 90mm)
500470	107	Liquid detergent USA
500489	41	Door lock
500544	105	Electronic coin meter (for coinbox height 90mm)



## W575H Compass,W5105H Compass,W5130H Compass,W5180H Compass,W5240H Compass,W5300H C

Table of contents	Innehållsförteckning	Page/Sida
Base and outer drum	Stativ och yttertrumma	7
Base and outer drum	Stativ och yttertrumma	9
Base and outer drum	Stativ och yttertrumma	11
Base and outer drum	Stativ och yttertrumma	15
Base and outer drum	Stativ och yttertrumma	19
Base and outer drum	Stativ och yttertrumma	23
Lining and top panel	Klädselplåtar och topplock	25
Lining and top panel	Klädselplåtar och topplock	29
Drum, rear gable	Trumma,bakgavel	35
Door and hinged joint	Lucka och gångled	39
Door lock	Lucklås	41
Motor	Motor	45
Motor control unit	Motorstyrningsenhet	47
Power balance unit	Obalanskontroll enhet	49
Control panel	Manöverpanel	51
Control panel	Manöverpanel	53
CPU	CPU	55
Program selector	Programväljare	57
Electric components connection	Eldetaljer anslutning	61
Drain valve and hoses	Avloppsventil och slangar	63
Water connections	Vattenanslutningar	65
Inlet valves and cable set	Inloppsventiler och ledningssatser	67
Inlet valves and cable set	Inloppsventiler och ledningssatser	69
Inlet valves and cable set	Inloppsventiler och ledningssatser	71
Inlet valves and cable set	Inloppsventiler och ledningssatser	73
Inlet valves and cable set	Inloppsventiler och ledningssatser	75
Inlet valves and cable set	Inloppsventiler och ledningssatser	77
Drain valve	Avloppsventil	79
Drain valve, electrical	Avloppsventil, elektrisk	81
*Drain pump	Avloppspump	83
Steam components	Ångdetaljer	85
Detergent container	Tvättmedelsbehållare	87
Out of balance switch	Obalansbrytare	89
Emergency stop	Nödstop	91
Key switch	Nyckelbrytare	93
Coinbox housing (for coinbox height 70mm)	Mynthus (för myntlåda höjd 70mm)	95
Coinbox housing (for coinbox height 90mm)	Mynthus (för myntlåda höjd 90mm)	97
Electronic coin meter	Elektronisk myntmätare	99
Coin meter	Myntmätare	101
Coin meter (for coinbox height 90mm)	Myntmätare (för myntlåda höjd 90mm)	103
Electronic coin meter (for coinbox height 90mm)	Elektronisk myntmätare (för myntlåda höjd 90mm)	105
Liquid detergent USA	Flytande tvättmedel USA	107

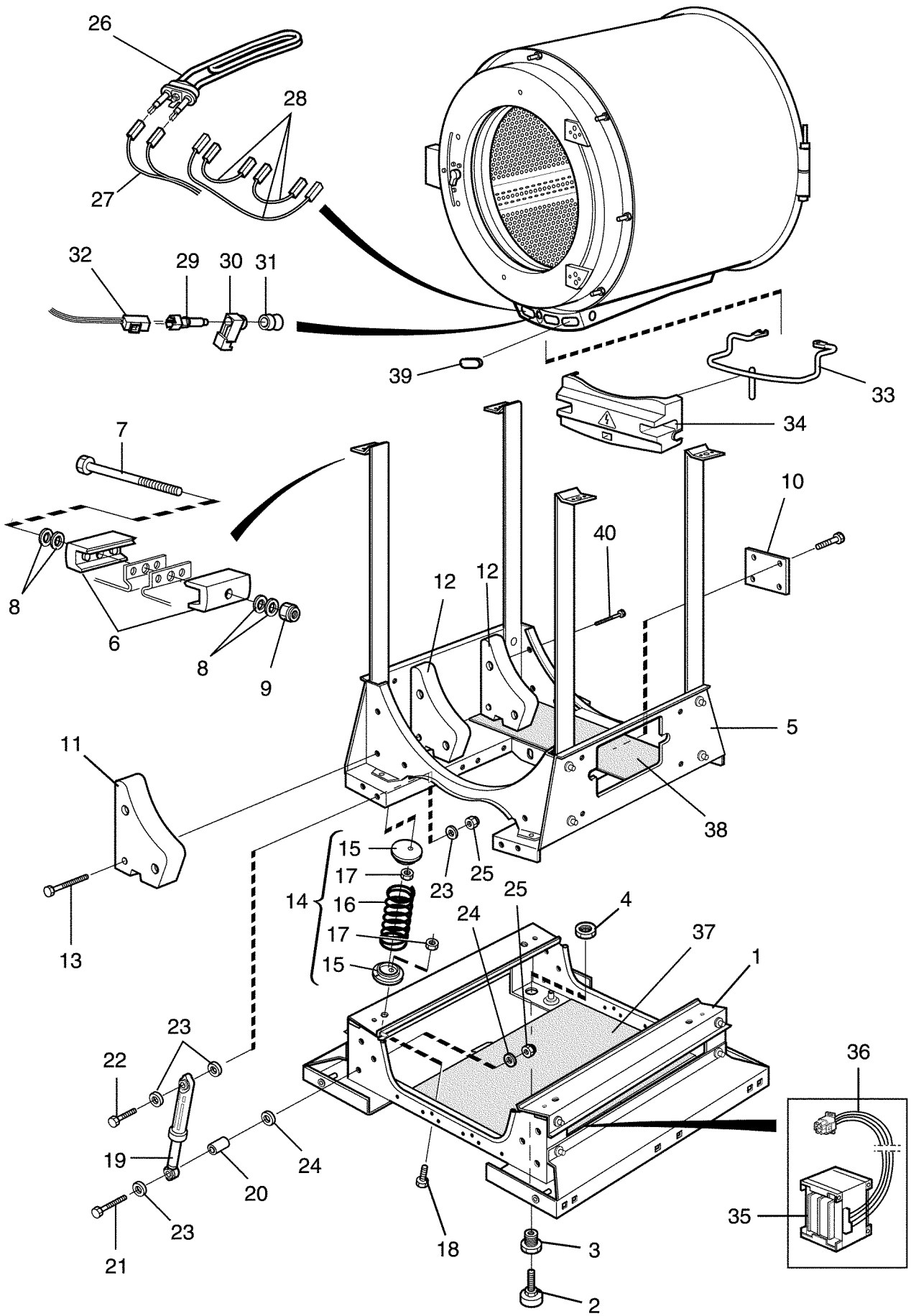

**W575H Compass****Base and outer drum**Illustration Issue Month Year  
Illustration Utgåva Månad År**Stativ och yttertrumma****500298 1 4 2013**

Item Pos.	Qua. Ant.	Art.No Art.nr	Description	Benämning	Info Info	Notes Anmärkning
1	1	432 1211-02	Frame	Stativ		Lower
2	4	438 8160-01	•Foot	•Fot		
3	4	432 1458-01	•Bushing	•Bussning		M10
4	4	471 8413-01	•Nut	•Mutter		M20
5	1	432 1212-03	Frame	Stativ		Upper
6	4	432 1453-01	•Tensioner	•Spänne		
7	2	725 2465-71	•Screw	•Skruv		M8X70
8	8	471 7807-02	•Tension plate	•Spännbricka		18x8,4x2
9	2	732 2118-01	•Locking nut	•Låsmutter		M8
10	1	432 1459-02	•Bracket	•Vridskydd		
11	2	432 1206-01	•Counterweight	•Motvikt		
12	Rq	432 1257-01	•Counterweight	•Motvikt		
13	6	471 8328-07	•Screw	•Skruv		M8X65
14	1	472 9913-03	Suspension	Fjäderenhhet		Kit compl.
15	8		•Spring retainer	•Fjäderfäste		
16	4		•Spring	•Fjäder		
17	8		•Nut	•Mutter		
18	8	471 8328-06	Screw	Skruv		
19	1	472 9913-08	Shock absorber	Stötdämpare		Complete kit, 4 pcs
20	4	471 8555-03	Bushing	Bussning		
21	4	725 2464-51	Screw	Skruv		M8X65
22	4	725 2461-51	Screw	Skruv		M8X50
23	12	471 8502-34	Washer	Bricka		8,4x24x2
24	12	471 8502-34	Washer	Bricka		8,4x24x2
25	8	732 2118-01	Locking nut	Låsmutter		M8
26	3	471 9837-01	Heating element	Element		2,5kW 240V
	3	471 9837-04	Heating element	Element		1kW 240V
	3	471 9837-05	Heating element	Element		1,8kW 240V
	3	471 9837-06	Heating element	Element		0,665kW 240V
	3	471 9837-07	Heating element	Element		2,5kW 254V
	3	471 9837-08	Heating element	Element		2,5kW 277V
	3	471 9839-01	Heating element	Element		2,5kW 240V Mop
27	1	432 2950-02	Cable set	Ledningssats		
28	1	432 2953-10	Cable set	Ledningssats		Kit
29	1	472 9904-98	Sensor	Givare		Complete
30	1		•Discharge	•Avlastning		
31	1		•Bushing	•Bussning		
32	1	413 3272-06	Cable set	Ledningssats		
33	1	432 1653-01	Clamp	Bygel		
34	1	432 1654-01	Cover	Skydd		
35	1	438 9569-01	Transformer	Transformator		200V
	1	438 9565-01	Transformer	Transformator		100-120V
	1	438 9566-01	Transformer	Transformator		400-480V
36	1	432 2985-01	Cable set	Ledningssats		200V
	1	432 2998-01	Cable set	Ledningssats		100-120V, 400-480V
37	1	438 7509-01	Insulation	Isolering		
38	Rq					Not used
39	Rq	471 9821-99	Plug	Propp		
40	6	471 8328-05	Screw	Skruv		M8X20

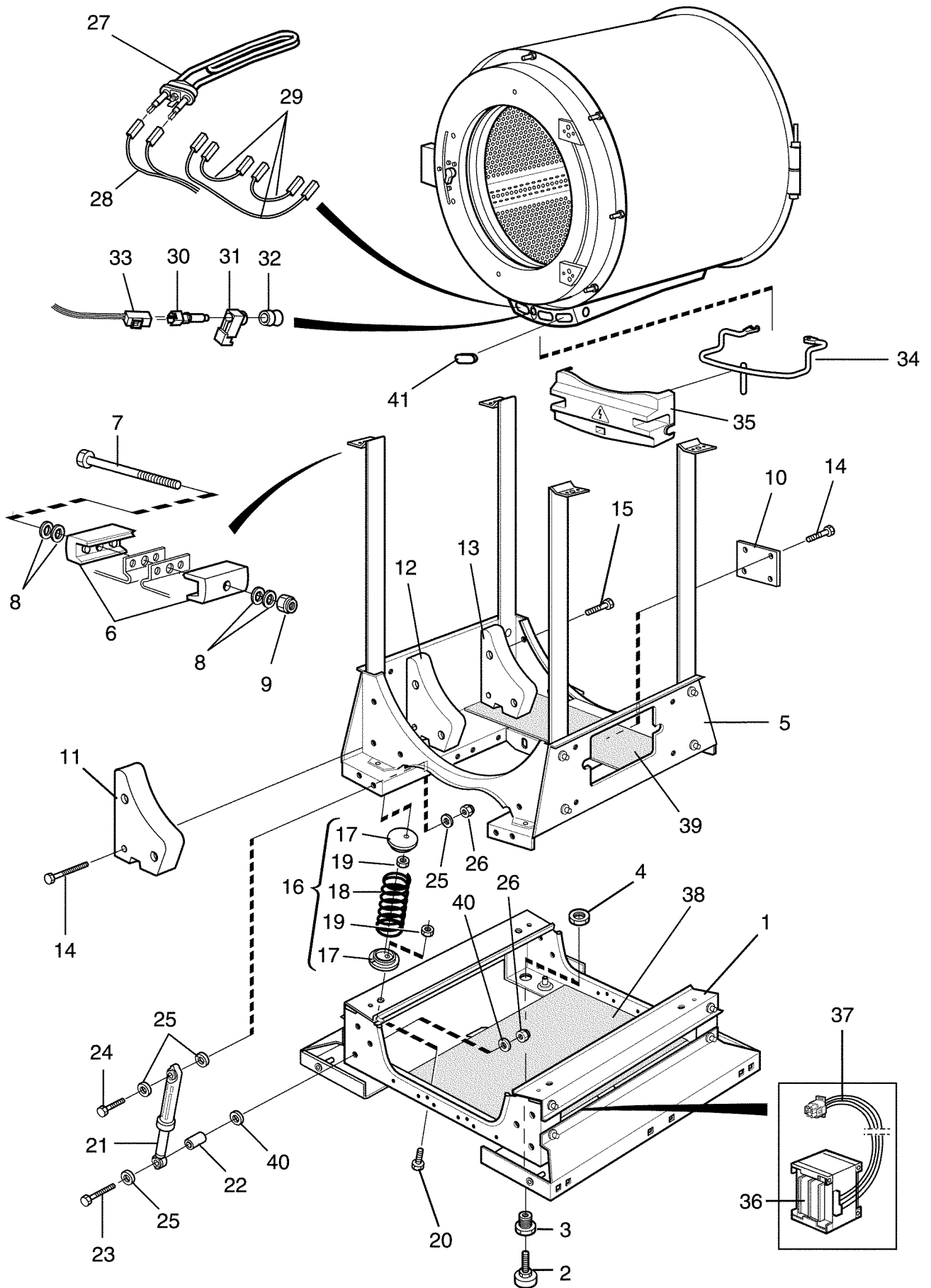



<b>W5105H Compass</b>					Illustration	Issue	Month	Year
<b>Base and outer drum</b>					Illustration	Utgåva	Månad	År
<b>Stativ och yttertrumma</b>					<b>500299</b>	<b>1</b>	<b>4</b>	<b>2013</b>
Item Pos.	Qua. Ant.	Art.No Art.nr	Description	Benämning	Info Info	Notes Anmärkning		
1	1	432 1261-01	Frame	Stativ		Lower		
2	4	438 8160-01	•Foot	•Fot				
3	4	432 1458-01	•Bushing	•Bussning		M10		
4	4	471 8413-01	•Nut	•Mutter		M20		
5	1	432 1262-02	Frame	Stativ		Upper		
6	4	432 1453-01	•Tensioner	•Spänne				
7	2	725 2465-71	•Screw	•Skruv		M8X70		
8	8	471 7807-02	•Tension plate	•Spännbricka		18x8,4x2		
9	2	732 2118-01	•Locking nut	•Låsmutter		M8		
10	1	432 1459-01	•Bracket	•Vridskydd				
11	2	432 1256-01	•Counterweight	•Motvikt				
12	2	432 1264-01	•Counterweight	•Motvikt				
13	2	432 1265-01	•Counterweight	•Motvikt				
14	6	471 8328-07	•Screw	•Skruv		M8X65		
15	10	471 8328-05	•Screw	•Skruv		M8X20		
16	1	472 9913-04	Suspension	Fjäderenhet		Kit compl.		
17	8		•Spring retainer	•Fjäderfäste				
18	4		•Spring	•Fjäder				
19	8		•Nut	•Mutter				
20	8	471 8328-06	Screw	Skruv				
21	1	472 9913-08	Shock absorber	Stötdämpare		Complete kit, 4 pcs		
22	4	471 8555-03	Bushing	Bussning				
23	4	725 2464-51	Screw	Skruv		M8X65		
24	4	725 2461-51	Screw	Skruv		M8X50		
25	12	471 8502-34	Washer	Bricka		8,4x24x2		
26	8	732 2118-01	Locking nut	Låsmutter		M8		
27	3	471 9837-11	Heating element	Element		3,33kW 240V		
	3	471 9837-12	Heating element	Element		2,5kW 240V		
	3	471 9837-13	Heating element	Element		3,33kW 254V		
	3	471 9837-15	Heating element	Element		3.3kW 277V		
	3	471 9837-14	Heating element	Element		1kW 240V		
	3	471 9839-11	Heating element	Element		3.33kW 240V Mop		
28	1	432 2950-02	Cable set	Ledningssats				
29	1	432 2953-10	Cable set	Ledningssats		Kit		
30	1	472 9904-98	Sensor	Givare		Complete		
31	1		•Discharge	•Avlastning				
32	1		•Bushing	•Bussning				
33	1	413 3272-09	Cable set	Ledningssats				
34	1	432 1653-01	Clamp	Bygel				
35	1	432 1654-01	Cover	Skydd				
36	1	438 9565-01	Transformer	Transformator		100-120V		
	1	438 9569-01	Transformer	Transformator		200V		
	1	438 9566-01	Transformer	Transformator		400-480V		
37	1	432 2985-01	Cable set	Ledningssats		200V		
	1	432 2998-01	Cable set	Ledningssats		100-120V, 400-480V		
38	1	438 7509-02	Insulation	Isolering				
39	1	438 7510-01	Insulation	Isolering				
40	8	471 8502-34	Washer	Bricka		8,4x24x2		
41	3	471 9821-99	Plug	Propp				

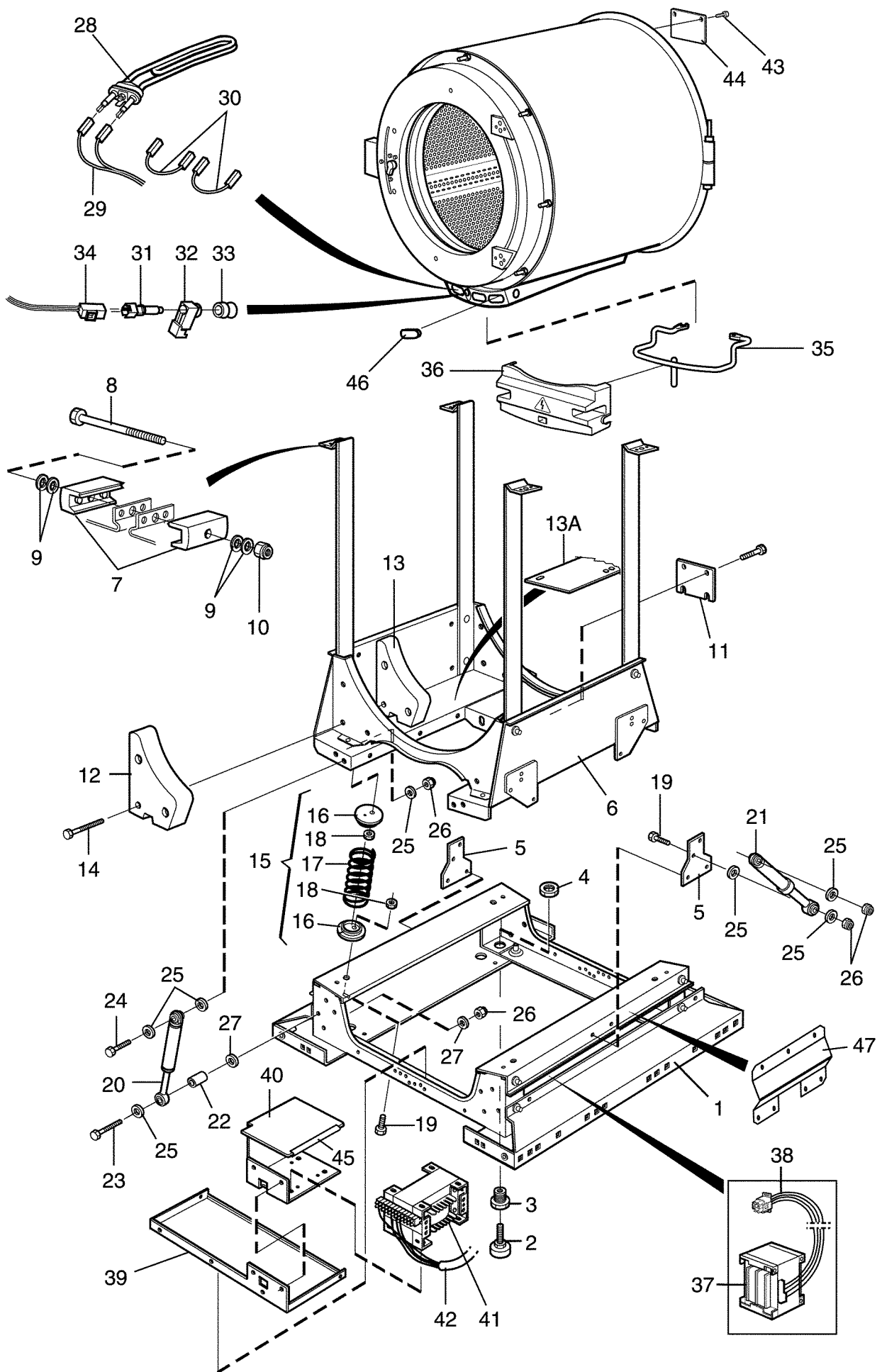

W5130H Compass					Illustration	Issue	Month	Year
Base and outer drum					Illustration	Utgåva	Månad	År
Stativ och yttertrumma					500300	1	4	2013
Item Pos.	Qua. Ant.	Art.No Art.nr	Description	Benämning	Info Info	Notes Anmärkning		
1	1	432 1311-01	Frame	Stativ		Lower		
2	4	438 8156-01	•Foot	•Fot		M10		
3	4	432 1458-01	•Bushing	•Bussning		M10		
4	4	471 8413-01	•Nut	•Mutter		M20		
5	2	432 1470-01	•Bracket	•Fäste		Middle		
6	1	432 1312-02	Frame	Stativ		Upper		
7	4	432 1453-01	•Tensioner	•Spänne				
8	2	725 2465-71	•Screw	•Skruv		M8X70		
9	8	471 7807-02	•Tension plate	•Spännbricka		18x8,4x2		
10	2	732 2118-01	•Locking nut	•Låsmutter		M8		
11	1	432 1650-01	•Bracket	•Fäste				
12	2	432 1306-01	•Counterweight	•Motvikt				
13	2	432 1307-01	•Counterweight	•Motvikt				
13A	1	413 5068-01	•Counterweight	•Motvikt				
14	6	471 8328-08	•Screw	•Skruv		M10X80		
15	1	472 9913-05	Suspension	Fjäderenhet		Kit compl.		
16	8		•Spring retainer	•Hållare fjäder				
17	4		•Spring	•Fjäder				
18	8		•Nut	•Mutter				
19	12	471 8328-05	Screw	Skruv		M8X20		
20	1	472 9913-09	Shock absorber	Stötdämpare		Complete kit, 4 pcs		
21	1	472 9913-11	Shock absorber	Stötdämpare		Complete kit, 2 pcs		
22	8	471 8555-03	Bushing	Bussning				
23	8	725 2464-51	Screw	Skruv		M8X65		
24	16	725 2461-51	Screw	Skruv		M8X50		
25	18	471 8502-34	Washer	Bricka		8,4x24x2		
26	12	732 2118-01	Locking nut	Låsmutter		M8		
27	8	471 8502-34	Washer	Bricka		8,4x24x2		
28	3	471 9825-01	Heating element	Element		4.33kW 240V		
	3	471 9825-02	Heating element	Element		4.33kW 254V		
	3	471 9825-03	Heating element	Element		1.6kW 240V		
	3	471 9825-04	Heating element	Element		4.33kW 277V		
	3	471 9829-01	Heating element	Element		4.33kW 240V MOP		
	3	471 9829-02	Heating element	Element		4.33kW 254V MOP		
	3	471 9829-04	Heating element	Element		4.33kW 277V MOP		
29	1	413 2965-12	Cable set	Ledningssats		400V		
	1	413 2965-13	Cable set	Kabelsats		230V		
	1	413 2965-24	Cable set	Ledningssats		EL/DS		
30	1	413 2965-11	Cable set	Ledningssats		400-480V		
31	1	472 9904-98	Sensor	Givare		Complete		
32	1		•Discharge	•Avlastning				
33	1		•Bushing	•Bussning				
34	1	413 3272-17	Cable set	Ledningssats				
35	1	432 1653-01	Clamp	Bygel				
36	1	432 1654-01	Cover	Skydd				
37	1	438 9569-01	Transformer	Transformator		200V		
38	1	432 2985-01	Cable set	Ledningssats		200V		
39	1	432 1418-01	Beam	Balk				
40	1	432 1295-01	Bracket	Konsol		Trafo 200V		
	1	432 1419-01	Bracket	Konsol				
41	1	438 9572-01	Transformer	Transformator		100-120V		
	1	438 9562-01	Transformer	Transformator		380-480V		
42	1	432 2977-01	Cable set	Ledningssats		100-120V 380-480V		
43	8	471 8328-05	Screw	Skruv		M8X20		
44	1	432 1649-01	Plate	Platta				
45	1	471 8180-10	Strip	List				
46	3	471 9822-99	Plug	Propp				
47	2	432 1438-01	Transport support	Transportstöd				

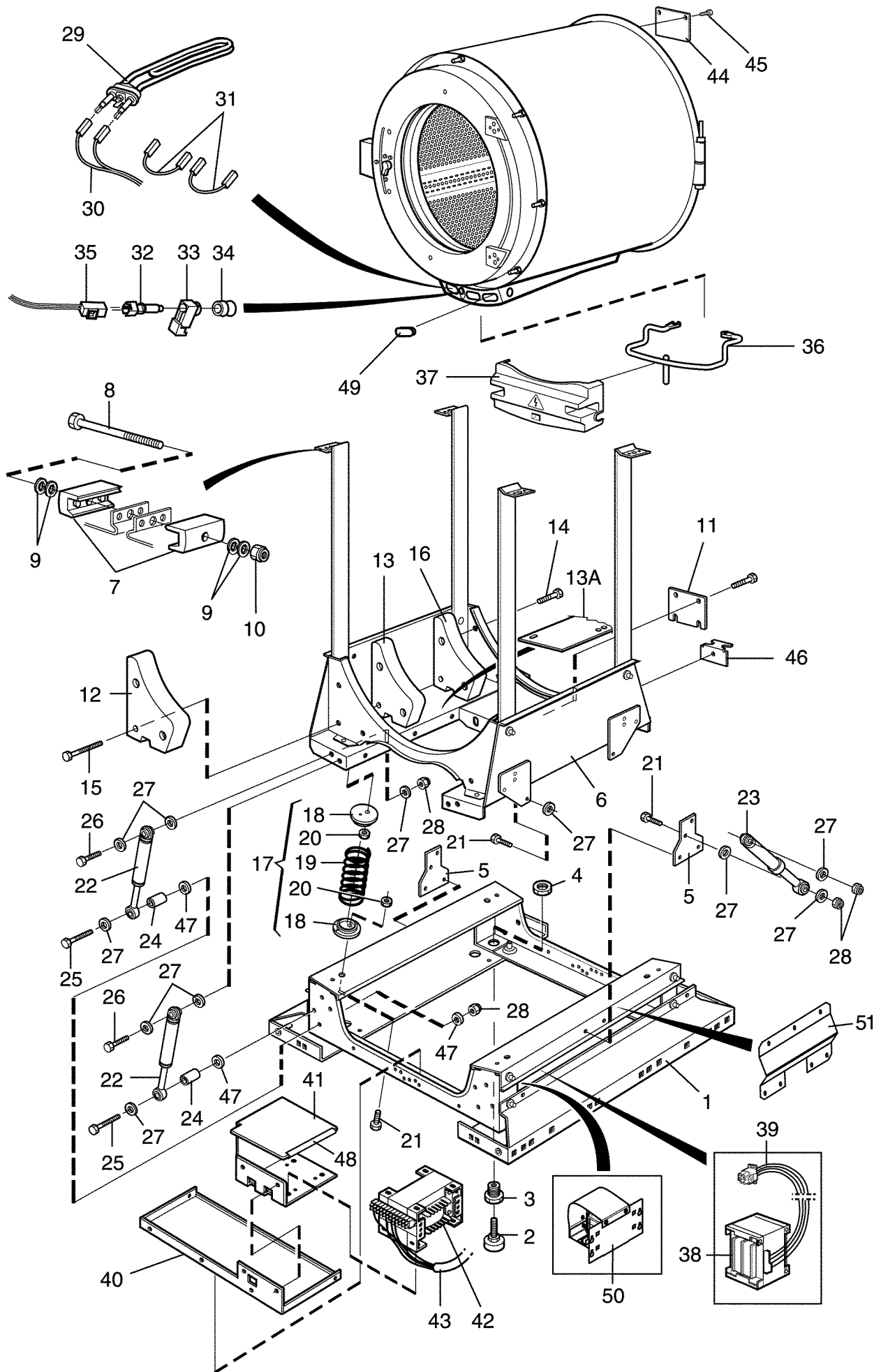

<b>W5180H Compass</b>				Illustration	Issue	Month	Year
<b>Base and outer drum</b>				Illustration	Utgåva	Månad	År
<b>Stativ och yttertrumma</b>				<b>500305</b>	<b>1</b>	<b>4</b>	<b>2013</b>
Item Pos.	Qua. Ant.	Art.No Art.nr	Description	Benämning	Info Info	Notes Anmärkning	
1	1	432 1361-01	Frame	Stativ		Lower	
2	4	438 8156-01	•Foot	•Fot		M10	
3	4	432 1458-01	•Bushing	•Bussning		M10	
4	4	471 8413-01	•Nut	•Mutter		M20	
5	2	432 1470-01	•Bracket	•Fäste		Middle	
6	1	432 1362-01	Frame	Stativ		Upper	
7	4	432 1453-01	•Tensioner	•Spänne			
8	2	725 2465-71	•Screw	•Skruv		M8X70	
9	8	471 7807-02	•Tension plate	•Spännbricka		18x8,4x2	
10	2	732 2118-01	•Locking nut	•Låsmutter		M8	
11	1	432 1651-01	•Bracket	•Vridskydd			
12	2	432 1356-01	•Counterweight	•Motvikt			
13	2	432 1357-01	•Counterweight	•Motvikt			
14	6	471 8328-09	•Screw	•Skruv		M10X20	
15	6	471 8328-11	•Screw	•Skruv			
16	2	432 1360-01	•Counterweight	•Motvikt			
16A	1	413 5068-01	•Counterweight	•Motvikt			
17	1	472 9913-06	Suspension	Fjäderenhet		Kit compl.	
18	8		•Spring retainer	•Fjäderfäste			
19	4		•Spring	•Fjäder			
20	8		•Nut	•Mutter			
21	8	471 8328-05	Screw	Skruv		M8X20	
22	1	472 9913-10	Shock absorber	Stötdämpare		Complete kit 8, pcs	
23	1	472 9913-11	Shock absorber	Stötdämpare		Complete kit, 2 pcs	
24	8	471 8555-03	Bushing	Bussning			
25	8	725 2464-51	Screw	Skruv		M8X65	
26	12	725 2461-51	Screw	Skruv		M8X50	
27	32	471 8502-34	Washer	Bricka		8,4x24x2	
28	20	732 2118-01	Locking nut	Låsmutter		M8	
29	3	471 9825-11	Heating element	Element		6kW 240V	
	3	471 9825-12	Heating element	Element		6kW 254V	
	3	471 9825-13	Heating element	Element		6kW 277V	
	3	471 9829-11	Heating element	Element		6kW 240V MOP	
	3	471 9829-12	Heating element	Element		6kW 254V MOP	
	3	471 9829-13	Heating element	Element		6kW 277V MOP	
30	1	413 2965-22	Cable set	Ledningssats		400V	
	1	413 2965-23	Cable set	Ledningssats		230V 1AC/230V 3AC	
	1	413 2965-24	Cable set	Ledningssats		EL/DS	
	1	413 2965-25	Cable set	Ledningssats		1AC 240V/3AC 415V	
31	2	413 2965-01	Cable set	Ledningssats		400V	
32	1	472 9904-98	Sensor	Givare		Complete	
33	1		•Discharge	•Avlastning			
34	1		•Bushing	•Bussning			
35	1	413 3272-22	Cable set	Ledningssats			
36	1	432 1653-01	Clamp	Bygel			
37	1	432 1654-01	Cover	Skydd			
38	1	438 9569-01	Transformer	Transformator		200V	
39	1	432 2985-01	Cable set	Ledningssats		200V	
40	1	432 1420-01	Beam	Balk			
41	1	432 1421-01	Bracket	Konsol			
	1	432 1295-01	Bracket	Konsol		Trafo 200V	
42	1	438 9573-01	Transformer	Transformator		100-120V	
	1	438 9563-01	Transformer	Transformator		380-480V	
43	1	432 2977-01	Cable set	Ledningssats		100-120V 380-480V	
44	1	432 1649-01	Plate	Platta			
45	8	471 8328-05	Screw	Skruv		M8X20	
46	2	432 1336-01	Guide	Styrning			
47	16	471 8502-34	Washer	Bricka		8,4x24x2	
48	1	471 8180-10	Strip	List			

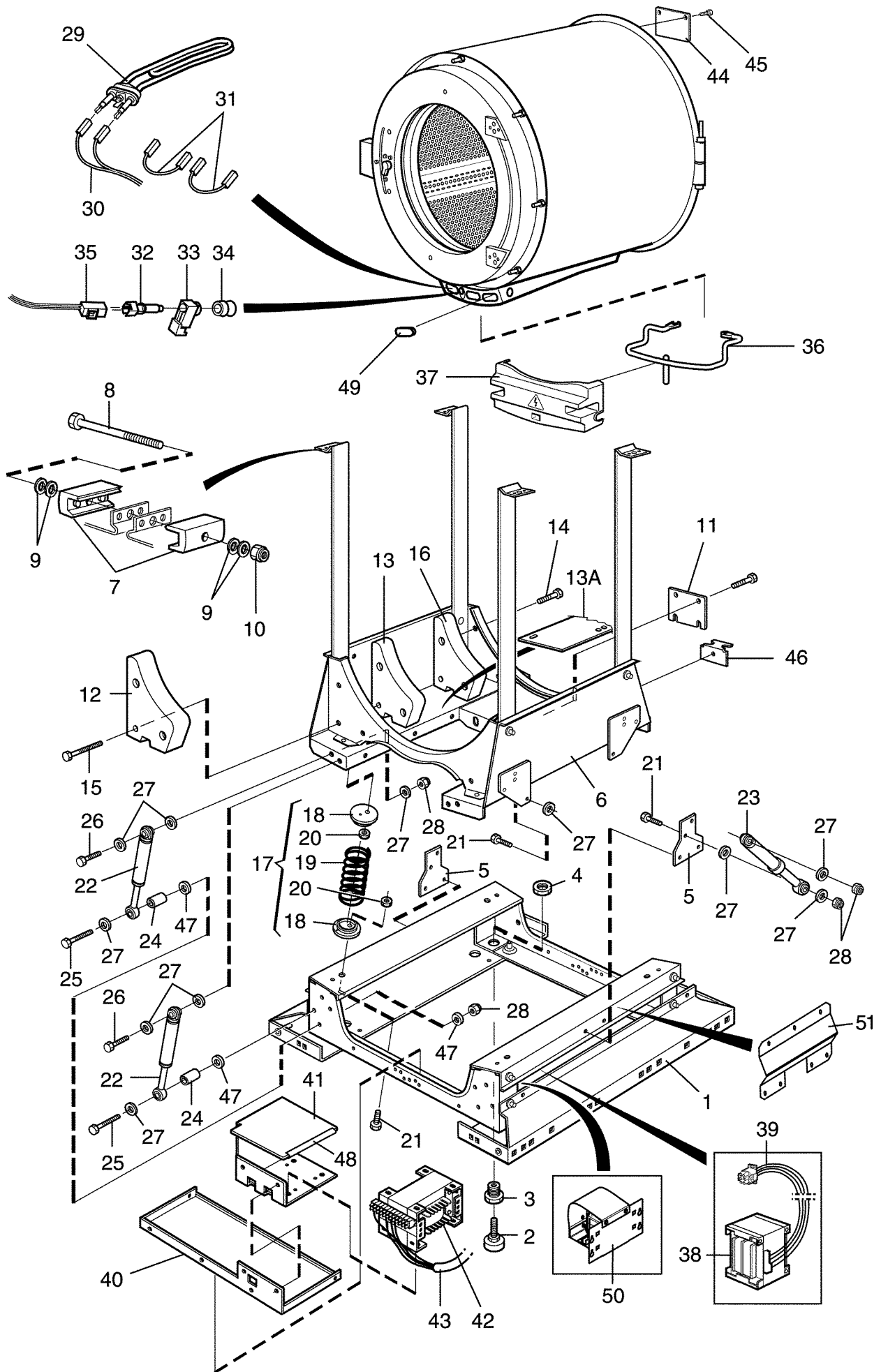

**W5180H Compass**

**Base and outer drum**

**Stativ och yttertrumma**

Illustration	Issue	Month	Year
Illustration	Utgåva	Månad	År
<b>500305</b>	<b>1</b>	<b>4</b>	<b>2013</b>

Item Pos.	Qua. Ant.	Art.No Art.nr	Description	Benämning	Info Info	Notes Anmärkning
49	3	471 9822-99	Plug	Propp		15A
50	1	413 3704-12	Choke	Choke		
51	2	432 1438-01	Transport support	Transportstöd		

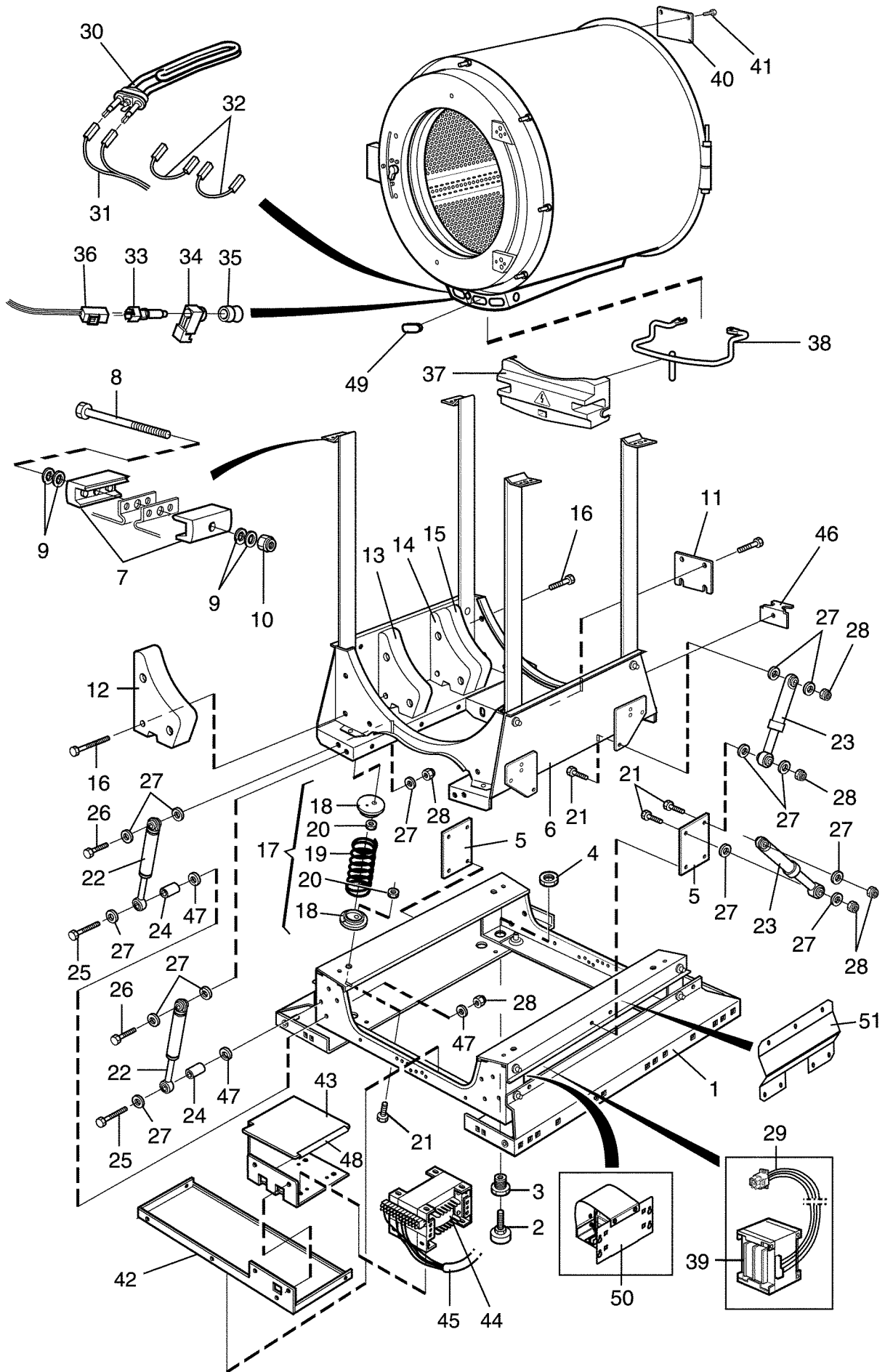



**W5240H Compass****Base and outer drum**

Illustration	Issue	Month	Year
Illustration	Utgåva	Månad	År
<b>500306</b>	<b>1</b>	<b>4</b>	<b>2013</b>

**Stativ och yttertrumma**

Item Pos.	Qua. Ant.	Art.No Art.nr	Description	Benämning	Info Info	Notes Anmärkning
1	1	432 1411-01	Frame	Stativ		Lower
2	4	438 8156-01	•Foot	•Fot		M10
3	4	432 1458-01	•Bushing	•Bussning		M10
4	4	471 8413-01	•Nut	•Mutter		M20
5	2	432 1468-01	•Bracket	•Fäste		Middle
6	1	432 1412-01	Frame	Stativ		Upper
7	4	432 1453-01	•Tensioner	•Spänne		
8	2	725 2465-71	•Screw	•Skruv		M8X70
9	8	471 7807-02	•Tension plate	•Spännbricka		18x8,4x2
10	2	732 2118-01	•Locking nut	•Låsmutter		M8
11	1	432 1652-01	•Bracket	•Vridskydd		
12	2	432 1406-01	•Counterweight	•Motvikt		
13	2	432 1406-02	•Counterweight	•Motvikt		
14	2	432 1407-01	•Counterweight	•Motvikt		
15	2	432 1407-02	•Counterweight	•Motvikt		
16	12	471 8328-08	•Screw	•Skruv		M10X80
17	1	472 9913-07	Suspension	Fjäderenhhet		Kit compl.
18	8		•Spring retainer	•Fjäderfäste		
19	4		•Spring	•Fjäder		
20	8		•Nut	•Mutter		
21	14	471 8328-09	Screw	Skruv		M10X20
22	1	472 9913-10	Shock absorber	Stötdämpare		Complete kit 8, pcs
23	1	472 9913-08	Shock absorber	Stötdämpare		Complete kit, 4 pcs
24	8	471 8555-03	Bushing	Bussning		
25	8	725 2464-51	Screw	Skruv		M8X65
26	16	725 2461-51	Screw	Skruv		M8X50
27	Rq	471 8502-34	Washer	Bricka		8,4x24x2
28	Rq	732 2118-01	Locking nut	Låsmutter		M8
29	1	432 2985-01	Cable set	Ledningssats		200V
30	3	471 9825-24	Heating element	Element		6.36kW 230V
	3	471 9825-21	Heating element	Element		6.6kW 240V
	3	471 9825-22	Heating element	Element		7kW 254V
	3	471 9825-23	Heating element	Element		7.6kW 277V
	3	471 9829-21	Heating element	Element		7.66kW 240V MOP
	3	471 9829-22	Heating element	Element		7.66kW 254V MOP
	3	471 9829-23	Heating element	Element		7.66kW 277V MOP
31	1	413 2965-04	Cable set	Ledningssats		EL/DS
	1	413 2965-02	Cable set	Ledningssats		400V
	1	413 2965-05	Cable set	Ledningssats		1AC 230V/3AC 415V
	1	413 2965-03	Cable set	Ledningssats		230V
32	2	413 2965-01	Cable set	Ledningssats		400V
33	1	472 9904-98	Sensor	Givare		Complete
34	1		•Discharge	•Avlastning		
35	1		•Bushing	•Bussning		
36	1	413 3272-15	Cable set	Ledningssats		
37	1	432 1654-01	Cover	Skydd		
38	1	432 1653-01	Clamp	Bygel		
39	1	438 9569-01	Transformer	Transformator		200V
40	1	432 1649-01	Plate	Platta		
41	8	471 8328-05	Screw	Skruv		M8X20
42	1	432 1426-01	Beam	Balk		
43	1	432 1421-01	Bracket	Konsol		
	1	432 1295-01	Bracket	Konsol		Trafo 200V
44	1	438 9573-01	Transformer	Transformator		100-120V
	1	438 9563-01	Transformer	Transformator		380-480V
45	1	432 2977-01	Cable set	Ledningssats		100-120V 380-480V
46	2	432 1335-01	Guide	Styrning		
47	16	471 8502-34	Washer	Bricka		8,4x24x2
48	4	471 8180-10	Strip	List		

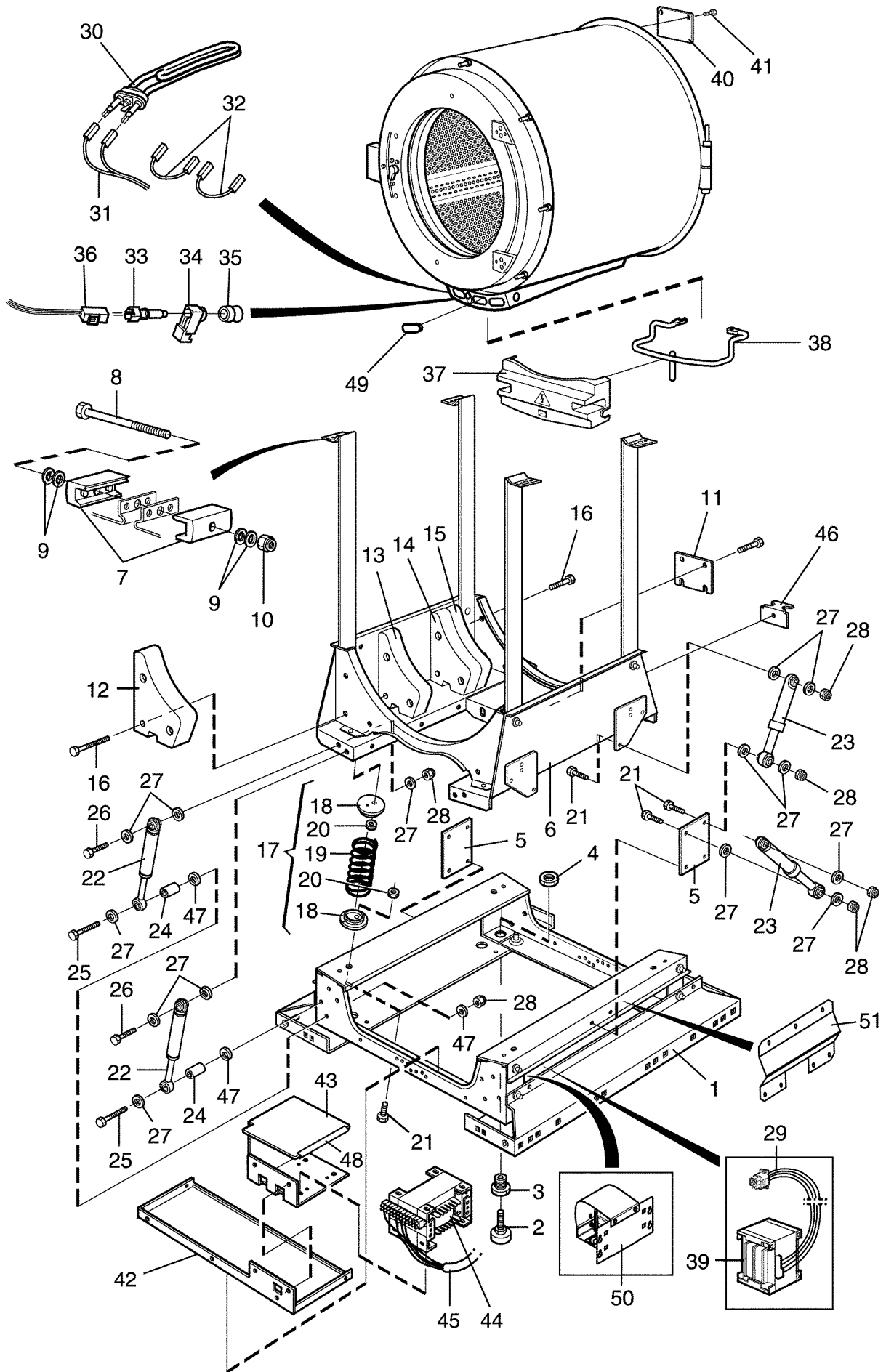

**W5240H Compass**

**Base and outer drum**

**Stativ och yttertrumma**

Illustration	Issue	Month	Year
Illustration	Utgåva	Månad	År
<b>500306</b>	<b>1</b>	<b>4</b>	<b>2013</b>

Item Pos.	Qua. Ant.	Art.No Art.nr	Description	Benämning	Info Info	Notes Anmärkning
49	3	471 9822-99	Plug	Propp		
50	1	413 3704-12	Choke	Choke		15A
51	2	432 1438-01	Transport support	Transportstöd		

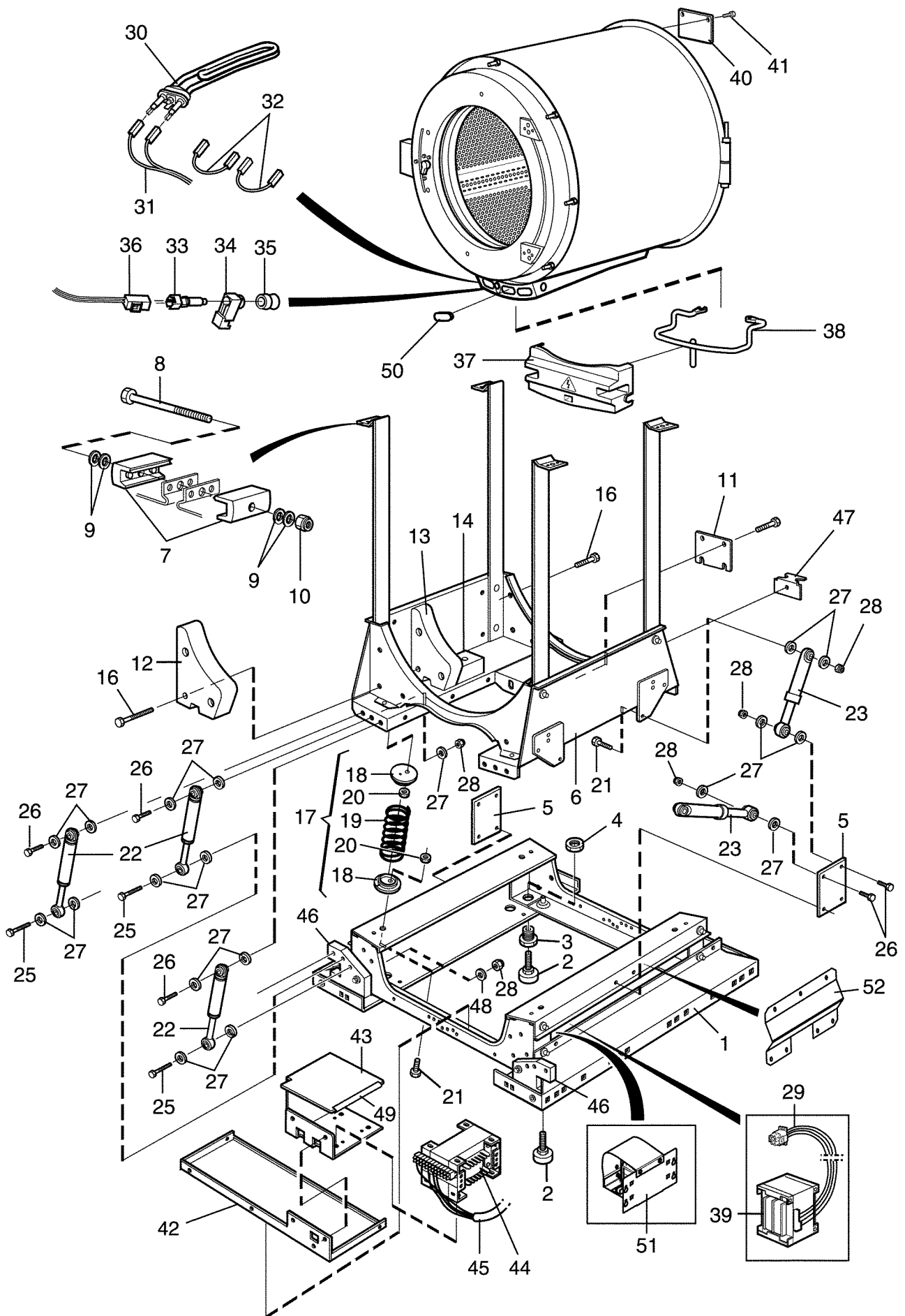

**W5300H Compass****Base and outer drum**

Illustration	Issue	Month	Year
Illustration	Utgåva	Månad	År
<b>500307</b>	<b>1</b>	<b>4</b>	<b>2013</b>

**Stativ och yttertrumma**

Item Pos.	Qua. Ant.	Art.No Art.nr	Description	Benämning	Info Info	Notes Anmärkning
1	1	432 1413-01	Frame	Stativ		Lower
2	4	438 8156-03	•Foot	•Fot		M12
3	Rq					Not used
4	4	471 8413-01	•Nut	•Mutter		M20
5	2	432 1468-01	•Bracket	•Fäste		Middle
6	1	432 1414-01	Frame	Stativ		Upper
7	4	432 1453-01	•Tensioner	•Spänne		
8	2	725 2465-71	•Screw	•Skruv		M8X70
9	8	471 7807-02	•Tension plate	•Spännbricka		18x8,4x2
10	2	732 2118-01	•Locking nut	•Låsmutter		M8
11	1		•Bracket	•Vridskydd		
12	1	432 1406-01	•Counterweight	•Motvikt		Left
	1	432 1406-02	•Counterweight	•Motvikt		Right
13	1	432 1407-01	•Counterweight	•Motvikt		Left
	1	432 1407-02	•Counterweight	•Motvikt		Right
14	2	432 1437-01	•Counterweight	•Motvikt		
15	Rq					Not used
16	12	471 8328-08	•Screw	•Skruv		M10X80
17	1	472 9913-63	Suspension	Fjäderenhet		Kit compl.
18	8		•Spring retainer	•Fjäderfäste		
19	4		•Spring	•Fjäder		
20	8		•Nut	•Mutter		
21	14	471 8328-09	Screw	Skruv		M10X20
22	1	472 9913-33	Shock absorber	Stötdämpare		Complete kit 10 pcs
23	1	472 9913-08	Shock absorber	Stötdämpare		Complete kit, 4 pcs
24	6	471 8555-03	Bushing	Bussning		
25	9	725 2464-51	Screw	Skruv		M8X65
26	17	725 2461-51	Screw	Skruv		M8X50
27	Rq	471 8502-34	Washer	Bricka		8,4x24x2
28	Rq	732 2118-01	Locking nut	Låsmutter		M8
29	1	432 2985-01	Cable set	Ledningssats		200V
30	3	471 9825-24	Heating element	Element		6.36kW 230V
	3	471 9825-21	Heating element	Element		6.6kW 240V
	3	471 9825-22	Heating element	Element		7kW 254V
	3	471 9825-23	Heating element	Element		7.6kW 277V
	3	471 9829-21	Heating element	Element		7.66kW 240V MOP
	3	471 9829-22	Heating element	Element		7.66kW 254V MOP
	3	471 9829-23	Heating element	Element		7.66kW 277V MOP
31	1	413 2965-02	Cable set	Ledningssats		400V
	1	413 2965-03	Cable set	Ledningssats		230V
	1	413 2965-04	Cable set	Ledningssats		EL/DS
32	2	413 2965-01	Cable set	Ledningssats		400V 400V
33	1	472 9904-98	Sensor	Givare		Complete
34	1		•Discharge	•Avlastning		
35	1		•Bushing	•Bussning		
36	1	413 3272-15	Cable set	Ledningssats		
37	1	432 1654-01	Cover	Skydd		
38	1	432 1653-01	Clamp	Bygel		
39	1	438 9569-01	Transformer	Transformator		200V
40	1	432 1649-01	Plate	Platta		
41	8	471 8328-05	Screw	Skruv		M8X20
42	1	432 1426-01	Beam	Balk		
43	1	432 1421-01	Bracket	Konsol		
	1	432 1295-01	Bracket	Konsol		Trafo 200V
44	1	438 9573-01	Transformer	Transformator		100-120V
	1	438 9563-01	Transformer	Transformator		380-480V
45	1	432 2977-01	Cable set	Ledningssats		100-120V 380-480V
46	4	432 1399-02	Bracket	Fäste		
47	2	432 1335-01	Guide	Styrning		

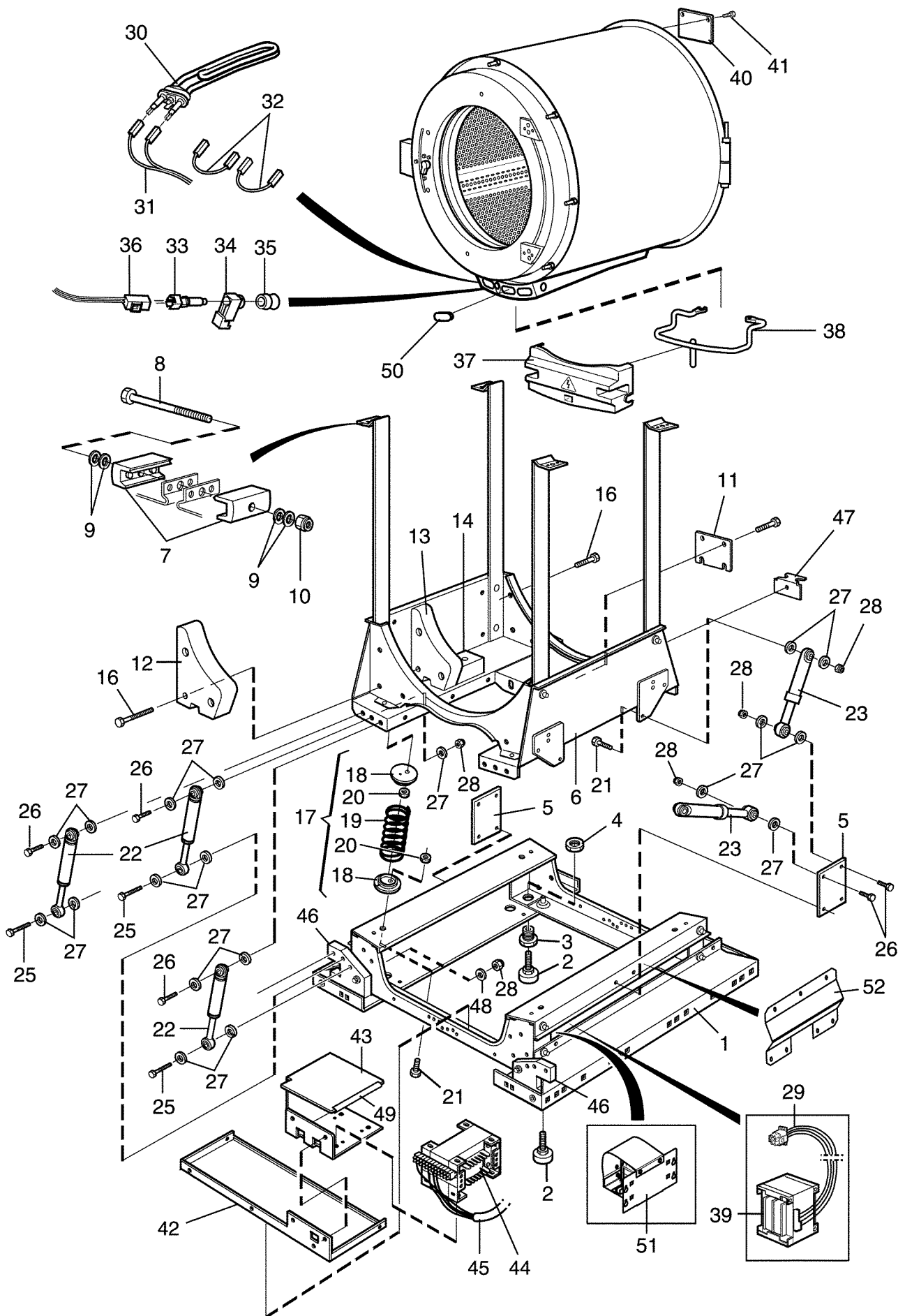

**W5300H Compass**

**Base and outer drum**

**Stativ och yttertrumma**

Illustration Issue Month Year  
 Illustration Utgåva Månad År  
**500307 1 4 2013**

Item Pos.	Qua. Ant.	Art.No Art.nr	Description	Benämning	Info Info	Notes Anmärkning
48	Rq	471 8502-34	Washer	Bricka		8,4x24x2
49	1	471 8180-10	Strip	List		
50	1	471 9822-99	Plug	Propp		
51	1	413 3704-12	Choke	Choke		15A
52	2	432 1438-02	Transport support	Transportstöd		

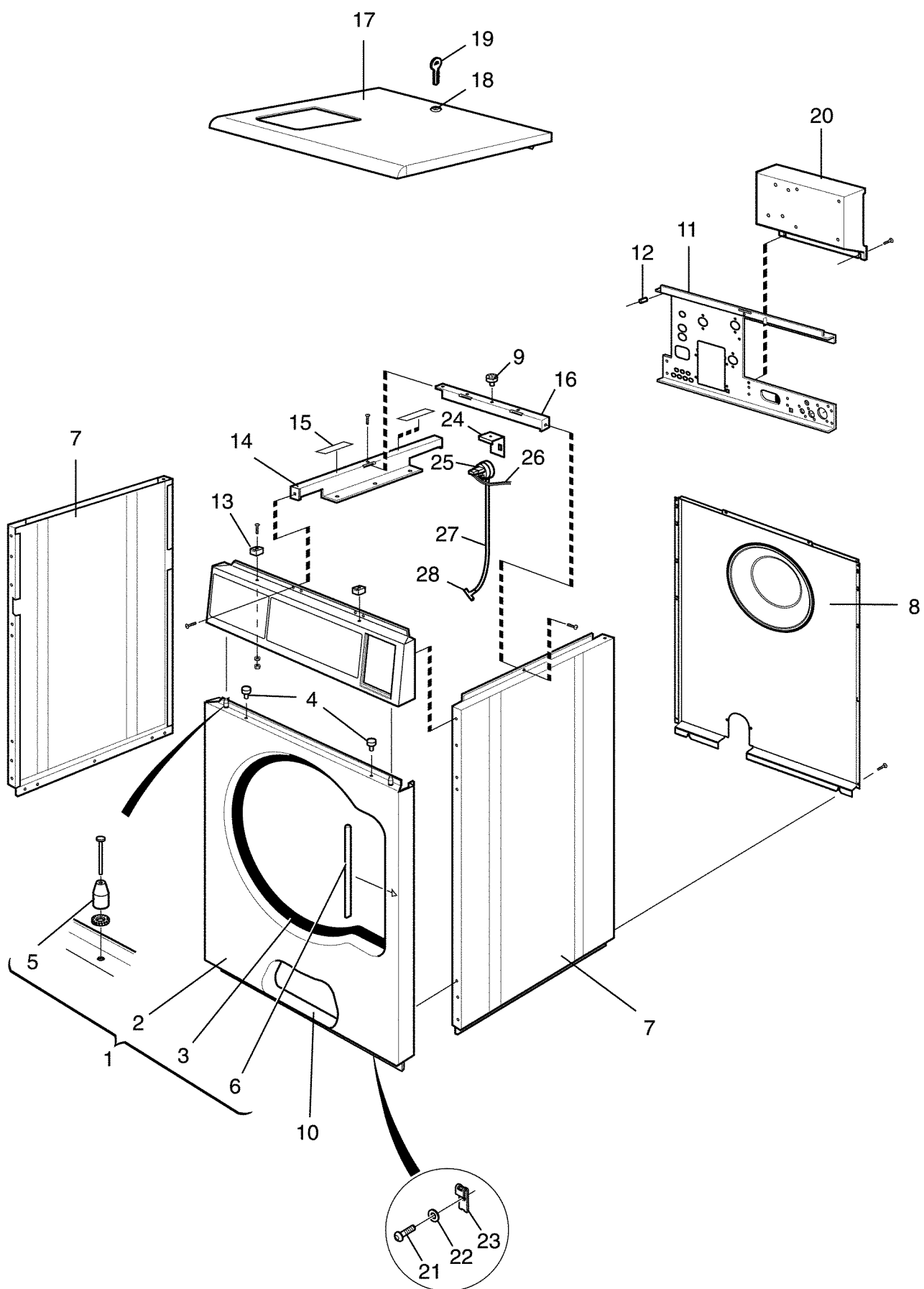



**W575H Compass,W5105H Compass**

**Lining and top panel**

Illustration Issue Month Year  
Illustration Utgåva Månad År  
**500280 1 4 2013**

**Klädselplåtar och topplock**

Item Pos.	Quantity Antal	Art.No Art.nr	Description	Benämning	Info Info	Notes Anmärkning
			W575H Compass			
			W5105H Compass			
1	1	472 9951-01	Front panel	Frontplåt		Grey/Blue Complete
	1	472 9951-11	Front panel	Frontplåt		Stainless Complete
	1	472 9951-21	Front panel	Frontplåt		White Complete
	1	472 9951-03	Front panel	Frontplåt		Grey/Blue Complete
	1	472 9951-13	Front panel	Frontplåt		Stainless Complete
	1	472 9951-23	Front panel	Frontplåt		White Complete
2	1	1	•Front panel	•Frontplåt		
3	1	432 2164-11	•Strip	•List		
	1	432 2164-12	•Strip	•List		
4	2	471 8196-01	•Plug	•Plugg		
5	2	438 5109-02	•Guide pin	•Styrpinne		
6	1	471 4672-67	•Protection	•Skydd		
7	2	432 2057-03	Side panel	Sidoplåt		Grey
	2	432 2057-10	Side panel	Sidoplåt		Stainless
	2	432 2058-03	Side panel	Sidoplåt		Grey
	2	432 2058-10	Side panel	Sidoplåt		Stainless
8	1	413 5006-01	Rear panel	Bakstycke		
	1	413 5008-01	Rear panel	Bakstycke		
9	1	471 8641-02	Plug	Propp		
10	1	438 7507-01	Insulation	Isolering		
11	1	432 2351-01	Brace bracket	Stagplåt		
	1	432 2354-01	Brace bracket	Stagplåt		
12	2	432 2180-01	Spacer	Distans		
13	2	432 2273-01	Guide	Styrning		
14	1	432 2130-01	Brace	Stag		
	1	432 2130-03	Brace	Stag		
15	4	471 7565-21	Velcro tape	Kardborreband		
16	1	432 2120-01	Brace	Stag		
	1	432 2122-01	Brace	Stag		
17	1	432 2280-65	Top panel	Topplock		No detergent container
	1	432 2280-66	Top panel	Topplock		With lock
	1	413 2201-21	Top panel	Topplock		No detergent container
	1	413 2201-22	Top panel	Topplock		With lock
	1	432 2281-65	Top panel	Topplock		
	1	432 2281-66	Top panel	Topplock		No detergent container
	1	413 2201-23	Top panel	Topplock		With lock Coin-meter
	1	413 2201-24	Top panel	Topplock		No detergent container
	1					With lock
18	1	471 7826-10	•Lock	•Lås		
19	1	472 9900-99	•Key	•Nyckel		SET
20	1	432 2215-01	Plate	Plåt		
21	2	471 8344-35	Screw	Skruv		M6X16
22	2	735 2153-01	Lock washer	Låsbricka		6,4
23	2	471 7864-01	Clip	Clips		M6
24	1	432 6318-01	Bracket	Hållare		
25	1	471 8861-02	Level control	Nivåkontroll		
26	1	413 2915-02	Cable set	Ledningssats		MOP Heating
	1	413 2915-01	Cable set	Ledningssats		
27	1	471 2436-10	Hose	Slang		
28	1	471 2265-69	T-pipe	T-rör		

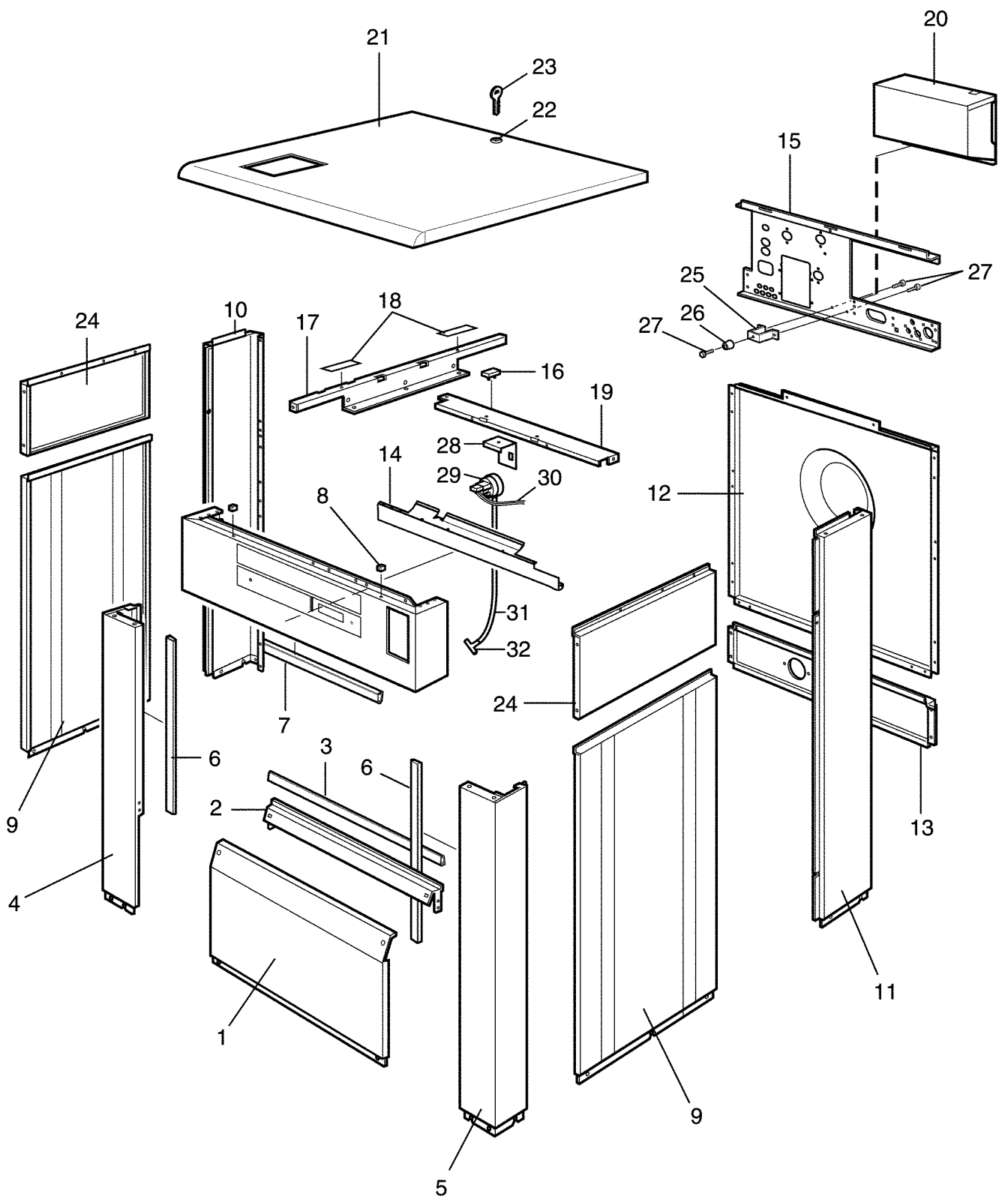

**W5130H Compass,W5180H Compass,W5240H Compass,W5300H Compass**

**Lining and top panel**

Illustration Issue Month Year  
Illustration Utgåva Månad År  
**500301 3 2 2015**

**Klädselplåtar och topplock**

Item Pos.	Quantity Antal	Art.No Art.nr	Description	Benämning	Info Info	Notes Anmärkning
			W5130H Compass			
			W5180H Compass			
			W5240H Compass			
			W5300H Compass			
1	1	432 2002-01	Front plate	Frontplåt		Stainless
	1	432 2003-01	Front plate	Frontplåt		Stainless
	1	432 2004-01	Front plate	Frontplåt		Stainless
2	1	432 2135-01	Brace	Stag		
	1	432 2135-02	Brace	Stag		
3	1	432 2163-13	Rubber strip	Gummilist		L=725
4	1	432 2050-01	Pillar	Stolpe		Stainless Left
	1	432 2051-01	Pillar	Stolpe		Stainless Left
	1	432 2052-01	Pillar	Stolpe		Stainless Left
5	1	432 2050-02	Pillar	Stolpe		Stainless Right
	1	432 2051-02	Pillar	Stolpe		Stainless Right
	1	432 2052-02	Pillar	Stolpe		Stainless Right
6	2	432 2163-11	Rubber strip	Gummilist		L=665
	2	432 2163-13	Rubber strip	Gummilist		L=725
7	1	432 2163-13	Rubber strip	Gummilist		L=725
8	2	432 2273-01	Guide	Styrning		
9	2	432 2032-03	Side panel	Sidoplåt		Grey
	2	432 2032-10	Side panel	Sidoplåt		Stainless
	2	432 2034-03	Side panel	Sidoplåt		Grey
	2	432 2034-10	Side panel	Sidoplåt		Stainless
	2	432 2036-03	Side panel	Sidoplåt		Grey
	2	432 2036-10	Side panel	Sidoplåt		Stainless
	2	432 2207-33	Side panel	Sidoplåt		Grey
	2	432 2207-40	Side panel	Sidoplåt		Grey
10	1	432 2033-31	Side panel	Sidoplåt		Grey Left
	1	432 2033-10	Side panel	Sidoplåt		Stainless Left
	1	432 2035-31	Side panel	Sidoplåt		Grey Left
	1	432 2035-10	Side panel	Sidoplåt		Stainless Left
	1	432 2037-31	Side panel	Sidoplåt		Grey Left
	1	432 2037-10	Side panel	Sidoplåt		Stainless Left
	1	432 2059-05	Side panel	Sidoplåt		Grey Left
	1	432 2059-10	Side panel	Sidoplåt		Stainless Left
11	1	432 2033-32	Side panel	Sidoplåt		Grey
	1	432 2033-11	Side panel	Sidoplåt		Stainless Right
	1	432 2035-32	Side panel	Sidoplåt		Grey Right
	1	432 2035-11	Side panel	Sidoplåt		Stainless Right
	1	432 2037-32	Side panel	Sidoplåt		Grey Right
	1	432 2037-11	Side panel	Sidoplåt		Stainless Right
	1	432 2059-06	Side panel	Sidoplåt		Grey Right
	1	432 2059-11	Side panel	Sidoplåt		Stainless Right
12	1	432 2064-01	Rear panel	Bakstycke		Upper
	1	432 2066-01	Rear panel	Bakstycke		Upper
	1	432 2068-01	Rear panel	Bakstycke		Upper
13	1	432 2065-01	Rear panel	Bakstycke		Lower
	1	432 2067-01	Rear panel	Bakstycke		Lower
	1	432 2069-01	Rear panel	Bakstycke		Lower
14	1	432 2372-01	Brace	Stag		
15	1	432 2352-01	Brace bracket	Stagplåt		
	1	432 2355-01	Brace bracket	Stagplåt		
	1	432 2356-01	Brace bracket	Stagplåt		
16	2	471 8641-02	Plug	Propp		
	2	471 2437-15	Plug	Propp		
	2	471 8641-02	Plug	Propp		
17	1	432 2131-01	Brace	Stag		
	1	432 2131-02	Brace	Stag		

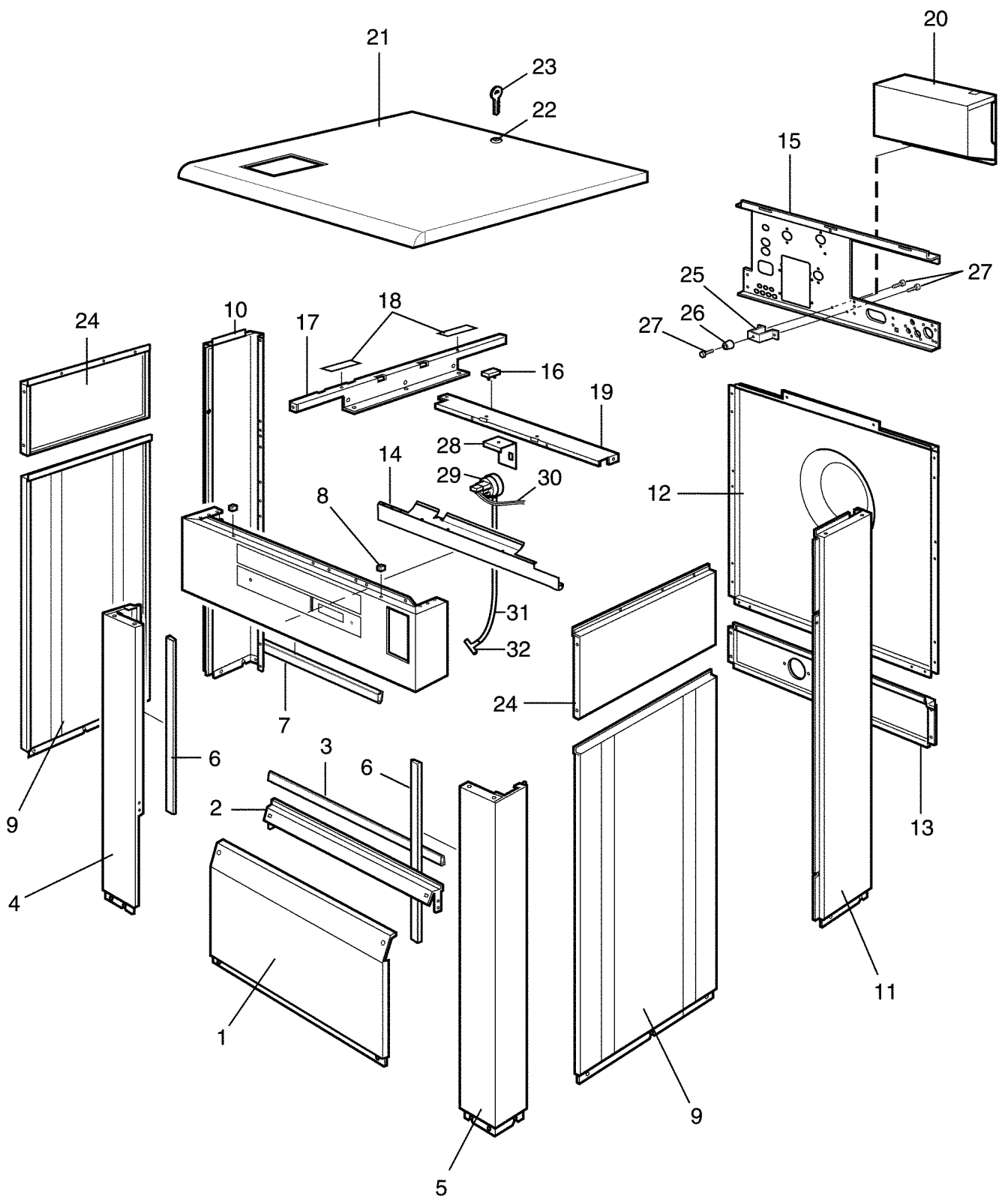

**W5130H Compass,W5180H Compass,W5240H Compass,W5300H Compass**

**Lining and top panel**

Illustration Issue Month Year  
Illustration Utgåva Månad År  
**500301 3 2 2015**

**Klädselplåtar och topplock**

Item Pos.	Quantity Antal		Art.No Art.nr	Description	Benämning	Info Info	Notes Anmärkning
				W5130H Compass			
				W5180H Compass			
				W5240H Compass			
				W5300H Compass			
18	4	4	4	5	432 2131-03 Brace	Stag	
19	1	1	1	1	432 2131-04 Brace	Stag	
	1	1	1	1	471 7565-21 Velcro tape	Kardborreband	
	1	1	1	1	432 2121-02 Brace	Stag	
	1	1	1	1	432 2121-03 Brace	Stag	
20	1	2	2	2	432 2121-04 Brace	Stag	
	1	1	1	1	432 2259-01 Plate	Plåt	
	1	1	1	1	432 2215-01 Plate	Plåt	
	1	1	1	1	432 2259-01 Plate	Plåt	
	1	1	1	1	432 2215-01 Plate	Plåt	
	1	1	1	1	432 2259-01 Plate	Plåt	
	1	1	1	1	432 2215-01 Plate	Plåt	
21	1	1	1	1	432 2259-01 Plate	Plåt	
	1	1	1	1	432 2215-01 Plate	Plåt	
	1	1	1	1	472 9952-08 Top panel	Topplöck	
	1	1	1	1	472 9952-10 Top panel	Topplöck	With lock
	1	1	1	1	472 9952-01 Top panel	Topplöck	No detergent container
	1	1	1	1	472 9952-02 Top panel	Topplöck	
	1	1	1	1	472 9952-11 Top panel	Topplöck	With lock
	1	1	1	1	472 9952-03 Top panel	Topplöck	No detergent container
	1	1	1	1	472 9952-04 Top panel	Topplöck	
	1	1	1	1	472 9952-12 Top panel	Topplöck	With lock
	1	1	1	1	472 9952-05 Top panel	Topplöck	No detergent container
	1	1	1	1	472 9952-06 Top panel	Topplöck	
	1	1	1	1	472 9952-13 Top panel	Topplöck	With lock
	1	1	1	1	472 9952-07 Top panel	Topplöck	No detergent container
22	1	1	1	1	471 7826-10 •Lock	•Lås	
23	1	1	1	1	472 9900-99 •Key	•Nyckel	SET
24	2	2	2	2	432 2038-03 Side panel	Sidoplåt	Grey Upper
	2	2	2	2	432 2038-10 Side panel	Sidoplåt	Stainless Upper
	2	2	2	2	432 2040-03 Side panel	Sidoplåt	Grey Upper
	2	2	2	2	432 2040-10 Side panel	Sidoplåt	Stainless Upper
25	1	1	1	1	432 2147-01 Bracket	Konsol	
	1	1	1	1	432 2139-01 Bracket	Konsol	
	1	1	1	1	432 2137-01 Bracket	Konsol	
26	1	1	1	1	471 7980-01 Stop	Stopp	
27	3	3	3	3	471 8342-15 Screw	Skruv	
28	1	1	1	1	432 6318-01 Bracket	Hållare	
29	1	1	1	1	471 8861-02 Level control	Nivåkontroll	
30	1	1	1	1	413 2915-01 Cable set	Ledningssats	
31	1	1	1	1	471 2436-10 Hose	Slang	
32	1	1	1	1	471 2265-69 T-pipe	T-rör	

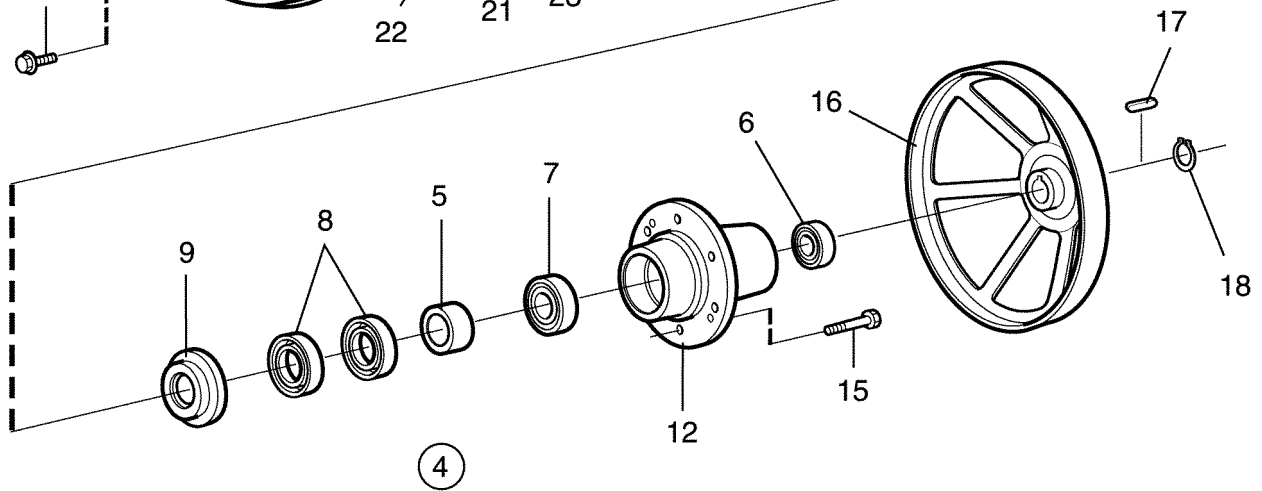
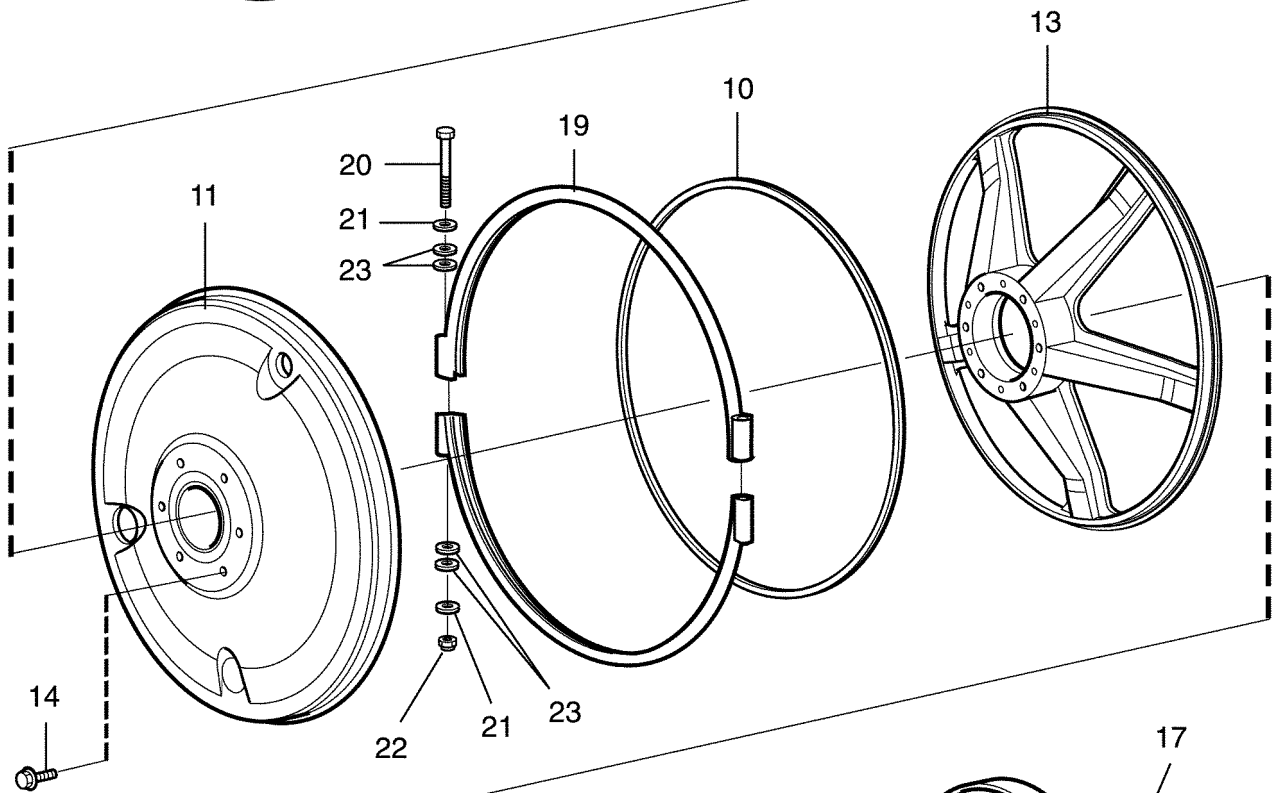
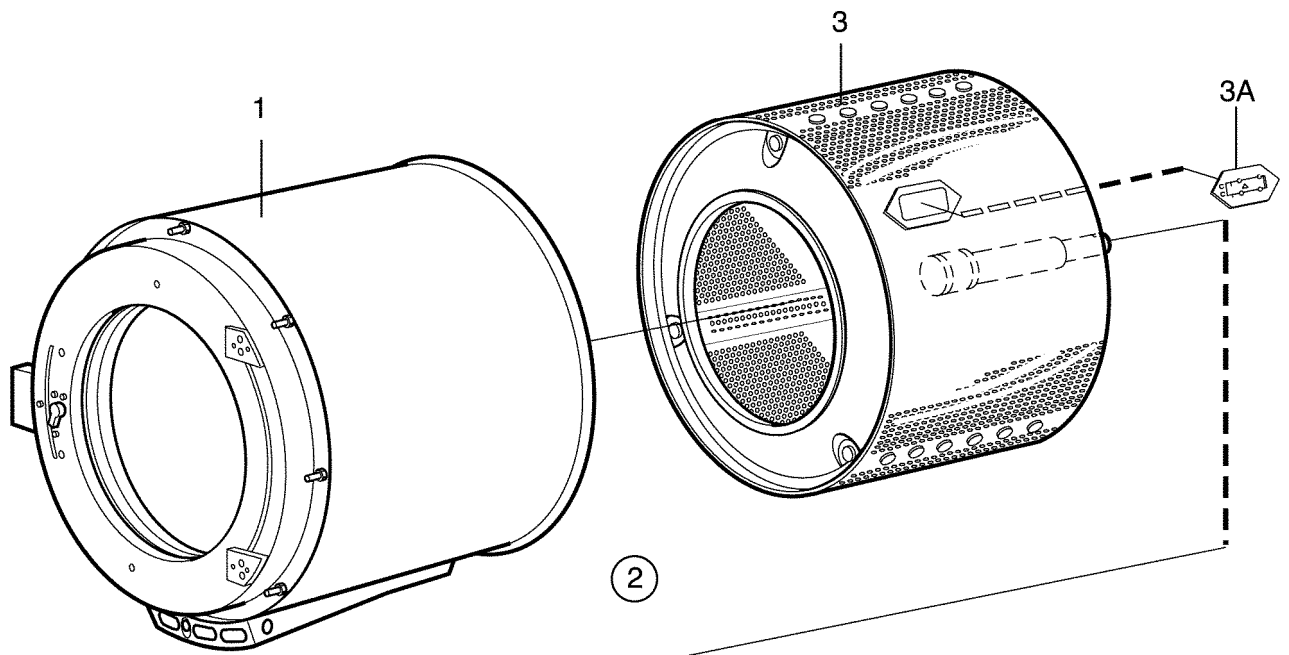

**W575H Compass,W5105H Compass,W5130H Compass,W5180H Compass,W5240H Compass,W5300H Compass**

**Drum, rear gable**

Illustration Issue Month Year  
Illustration Utgåva Månad År

**Trumma,bakgavel**

**500281 1 4 2013**

Item Pos.	Quantity Antal	Art.No Art.nr	Description	Benämning	Info Info	Notes Anmärkning	
1	W575H Compass						
	W5105H Compass						
	W5130H Compass						
	W5180H Compass						
	W5240H Compass						
	W5300H Compass						
	1	1	432 1570-11	Outer drum	Yttertrumma		Non-heated
		1	432 1570-12	Outer drum	Yttertrumma		El/Dual heating
		1	432 1570-13	Outer drum	Yttertrumma		Steam
		1	432 1571-01	Outer drum	Yttertrumma		Non-heated
		1	432 1571-02	Outer drum	Yttertrumma		El/Dual heating
		1	432 1571-03	Outer drum	Yttertrumma		Steam
		1	432 1572-01	Outer drum	Yttertrumma		Non-heated
		1	432 1572-02	Outer drum	Yttertrumma		El/Dual heating
		1	432 1572-03	Outer drum	Yttertrumma		Steam
		1	432 1573-01	Outer drum	Yttertrumma		Non-heated
		1	432 1573-02	Outer drum	Yttertrumma		El/Dual heating
		1	432 1573-03	Outer drum	Yttertrumma		Steam
		1	432 1574-01	Outer drum	Yttertrumma		Non-heated
		1	432 1574-02	Outer drum	Yttertrumma		El/Dual heating
		1	432 1574-03	Outer drum	Yttertrumma		Steam
2		1	432 1574-21	Outer drum	Yttertrumma	Non-heated	
		1	432 1574-22	Outer drum	Yttertrumma	EL.	
		1	432 1574-23	Outer drum	Yttertrumma	DS	
	1	1	432 1605-21	Rear gable	Bakgavel	Complete	
		1	432 1605-26	Rear gable	Bakgavel	Gas heated	
		1	432 1605-25	Rear gable	Bakgavel	Complete	
		1	432 1606-01	Rear gable	Bakgavel	MOP Complete	
		1	432 1606-02	Rear gable	Bakgavel	Complete	
		1	432 1606-06	Rear gable	Bakgavel	Gas Complete	
		1	432 1607-01	Rear gable	Bakgavel	MOP Complete	
		1	432 1607-02	Rear gable	Bakgavel	Without lubrication	
		1	432 1607-04	Rear gable	Bakgavel	DBS Level tube	
		1	432 1607-05	Rear gable	Bakgavel	Level tube	
		1	432 1607-07	Rear gable	Bakgavel	DBS	
		1	432 1608-01	Rear gable	Bakgavel	MOP Complete	
		1	432 1608-03	Rear gable	Bakgavel	Without lubrication	
		1	432 1608-07	Rear gable	Bakgavel	Level tube	
	3		1	432 1609-01	Rear gable	Bakgavel	MOP Complete
		1	432 1609-04	Rear gable	Bakgavel	Without lubrication	
		1	432 1609-07	Rear gable	Bakgavel	Level tube	
		1	432 1609-51	Rear gable	Bakgavel	MOP Complete	
		1	432 1609-52	Rear gable	Bakgavel	Complete	
		1	432 1609-53	Rear gable	Bakgavel	With level tube	
1		1	432 1500-11	•Inner drum	•Innertrumma	MOP Complete	
		1	432 1500-15	•Inner drum	•Innertrumma	MOP	
		1	432 1501-01	•Inner drum	•Innertrumma		
		1	432 1501-05	•Inner drum	•Innertrumma	MOP	
		1	432 1502-01	•Inner drum	•Innertrumma		
		1	432 1502-03	•Inner drum	•Innertrumma	DBS	
	1	432 1502-05	•Inner drum	•Innertrumma	MOP		
	1	432 1503-01	•Inner drum	•Innertrumma			
	1	432 1503-05	•Inner drum	•Innertrumma	MOP		
	1	432 1504-01	•Inner drum	•Innertrumma			
	1	432 1504-05	•Inner drum	•Innertrumma	MOP		

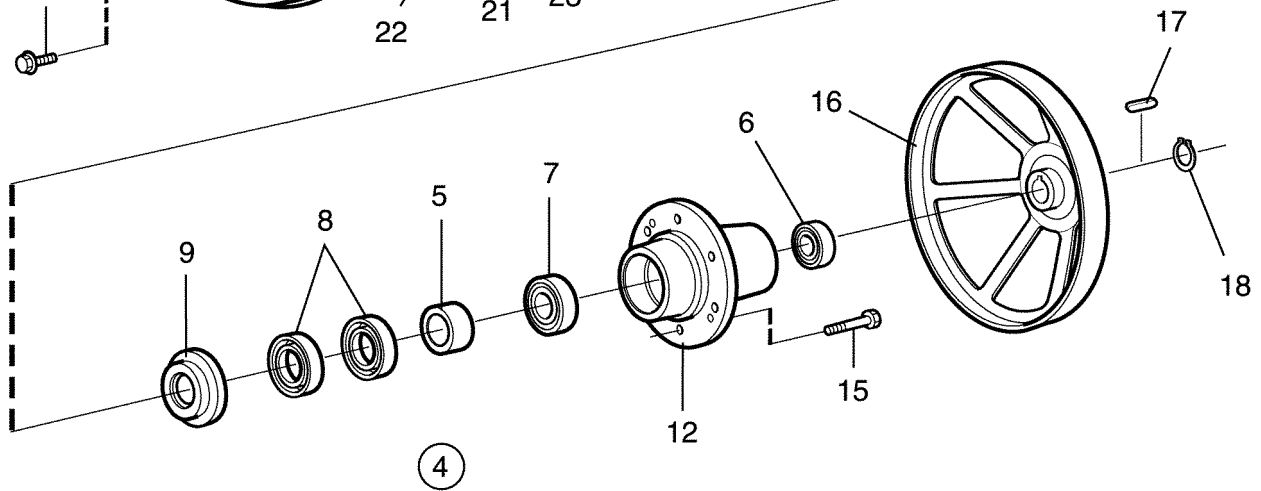
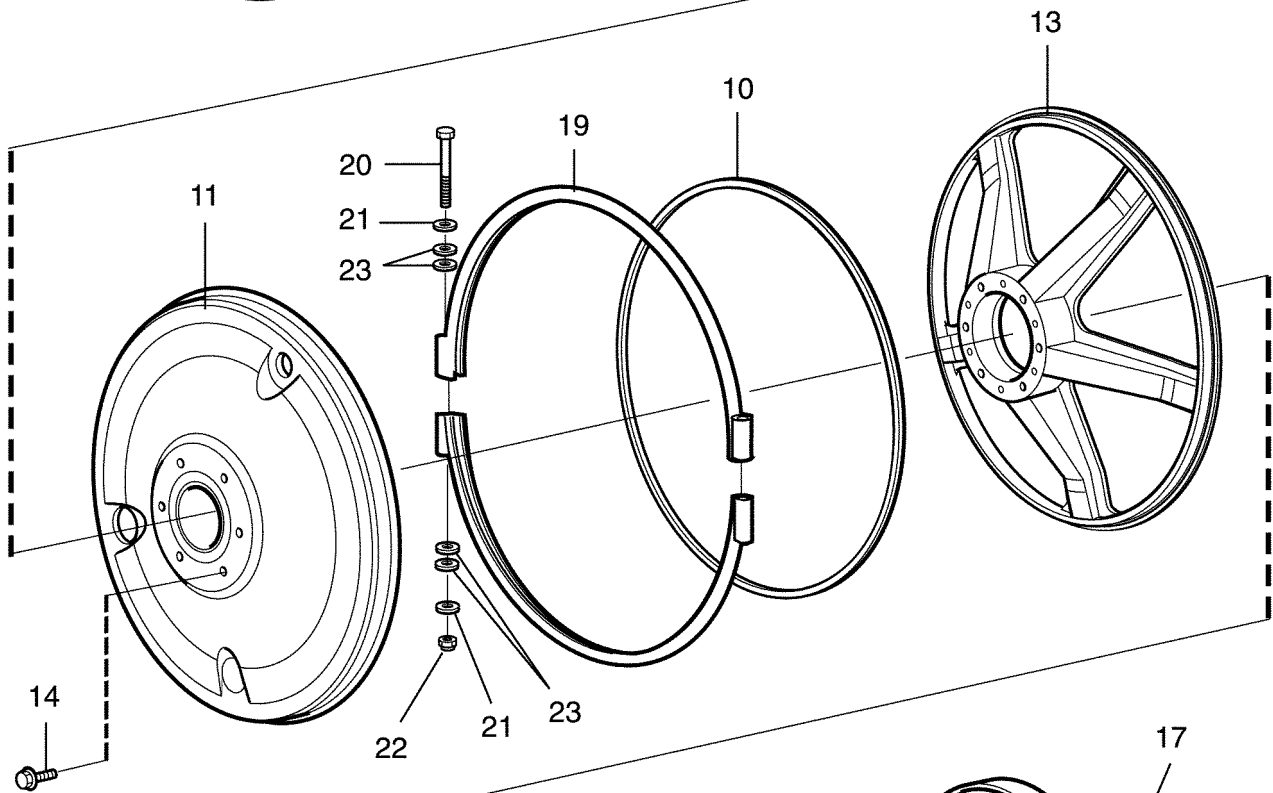
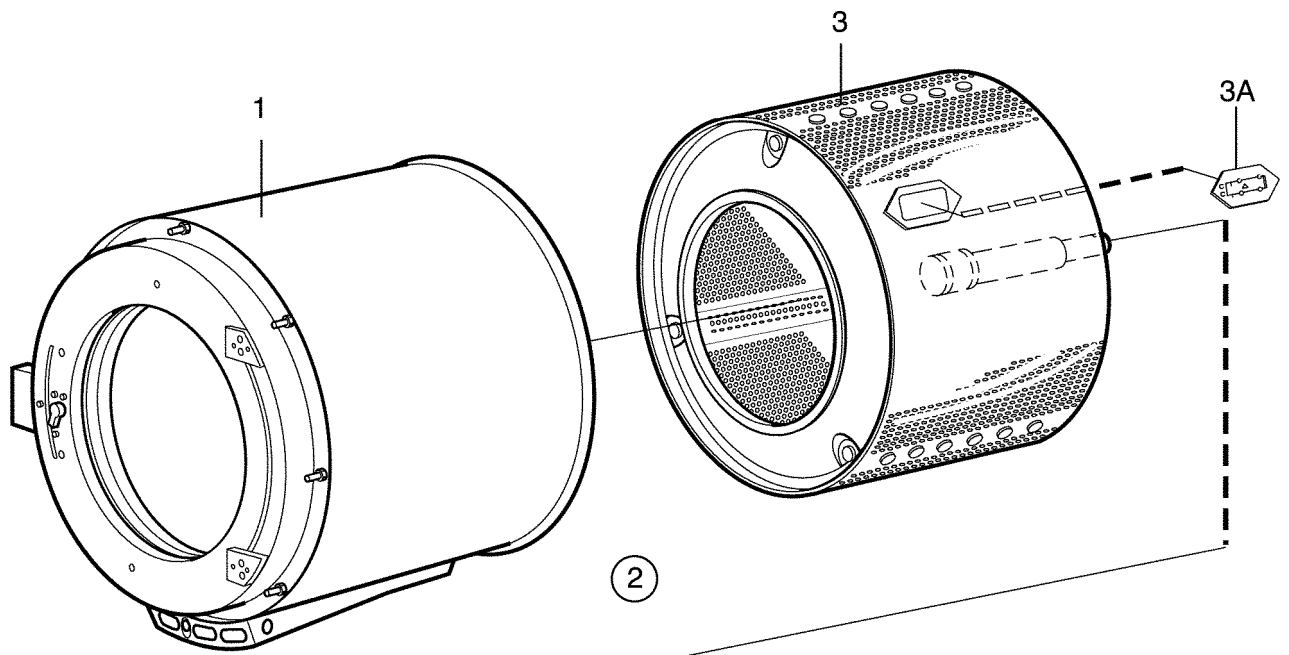



**W575H Compass,W5105H Compass,W5130H Compass,W5180H Compass,W5240H Compass,W5300H Compass**

**Drum, rear gable**

Illustration Issue Month Year  
Illustration Utgåva Månad År

**Trumma,bakgavel**

**500281 1 4 2013**

Item Pos.	Quantity Antal		Art.No Art.nr	Description	Benämning	Info Info	Notes Anmärkning				
				W575H Compass							
				W5105H Compass							
				W5130H Compass							
				W5180H Compass							
				W5240H Compass							
				W5300H Compass							
3A	1	1	2	2	2	2	2	432 1504-41 •Inner drum	•Innertrumma		
4	1							432 1504-42 •Inner drum	•Innertrumma		
		1						472 9768-01 •Door	•Lucka		MOP
			1					472 9913-12 •Repair kit	•Renoveringssats		
				1				472 9913-13 •Repair kit	•Renoveringssats		
					1			472 9913-17 •Repair kit	•Renoveringssats		
						1		472 9913-18 •Repair kit	•Renoveringssats		
							1	472 9913-19 •Repair kit	•Renoveringssats		
5	1	1	1	1	1	1	1	472 9913-64 •Repair kit	•Renoveringssats		
6	1	1	1	1	1	1	1	•Bushing	•Bussning		
7	1	1	1	1	1	1	1	•Ball bearing	•Kullager		
8	1	1	1	1	1	1	1	•Ball bearing	•Kullager		
9	2	2	2	2	2	2	2	•Sealing ring	•Tätning		
10	1	1	1	1	1	1	1	•Sealing ring	•Tätning		
								438 8155-01 •Seal	•Tätning		
								438 8155-02 •Seal	•Tätning		
								438 8155-03 •Seal	•Tätning		
								438 8155-04 •Seal	•Tätning		
								438 8155-05 •Seal	•Tätning		
11	1							432 1545-01 •Lining	•Klädselplåt		
	1							432 1655-01 •Lining	•Klädselplåt		Gas
								432 1546-01 •Lining	•Klädselplåt		
								432 1656-01 •Lining	•Klädselplåt		Gas
								432 1547-01 •Lining	•Klädselplåt		
								432 1548-01 •Lining	•Klädselplåt		
12	1							432 1549-01 •Lining	•Klädselplåt		
								432 1560-01 •Bearing housing	•Lagerhus		
								432 1561-01 •Bearing housing	•Lagerhus		
								432 1562-01 •Bearing housing	•Lagerhus		
								432 1563-01 •Bearing housing	•Lagerhus		
								432 1564-01 •Bearing housing	•Lagerhus		
13	1							432 1589-01 •Bearing housing	•Lagerhus		
								432 1540-01 •End piece	•Gavel		
								432 1541-01 •End piece	•Gavel		
								432 1542-01 •End piece	•Gavel		
								432 1543-01 •End piece	•Gavel		
								432 1544-01 •End piece	•Gavel		
14	6	8	8	10	10	10	10	471 8323-01 •Screw	•Skruv		M6X12
15	6	8	8	10	10	10	10	471 8328-02 •Screw	•Skruv		M12X50
16	1							432 1550-01 •Pulley	•Remskiva		
								432 1551-01 •Pulley	•Remskiva		
								432 1552-01 •Pulley	•Remskiva		
								432 1553-01 •Pulley	•Remskiva		
17	1							432 1554-01 •Pulley	•Remskiva		
								735 9370-01 •Wedge	•Kil		10x8x45
								735 9501-01 •Wedge	•Plattkil		14x9x50
18	1							735 9630-01 •Wedge	•Plattkil		18x11x63
								735 3133-00 •C-clamp	•Spårring		SGA35
								735 3139-00 •C-clamp	•Spårring		SGA 45
								735 3144-00 •C-clamp	•Spårring		SgA55
19	2							735 3147-00 •C-clamp	•Spårring		SGA 60
								432 1565-01 Tension strap	Spännband		
								432 1566-01 Tension strap	Spännband		

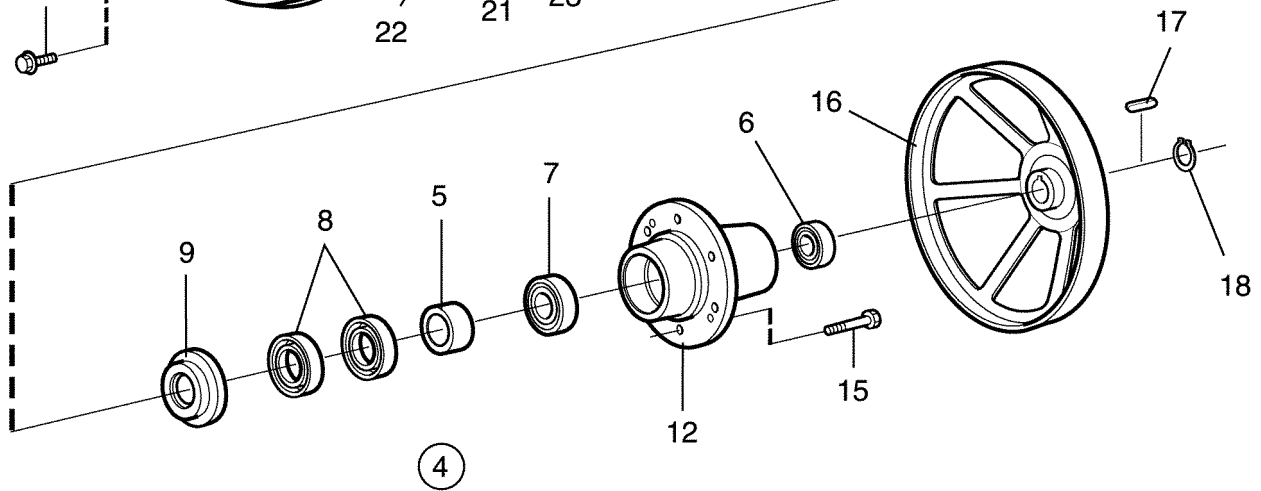
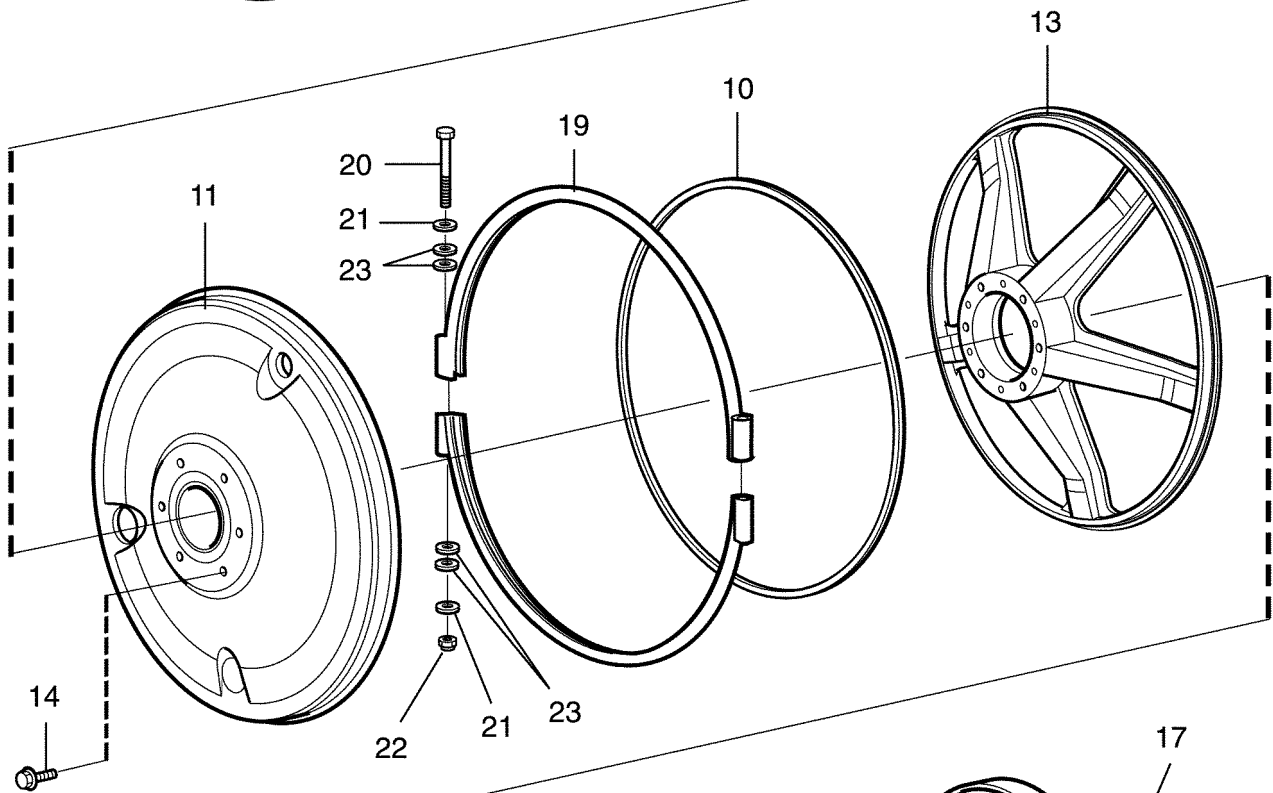
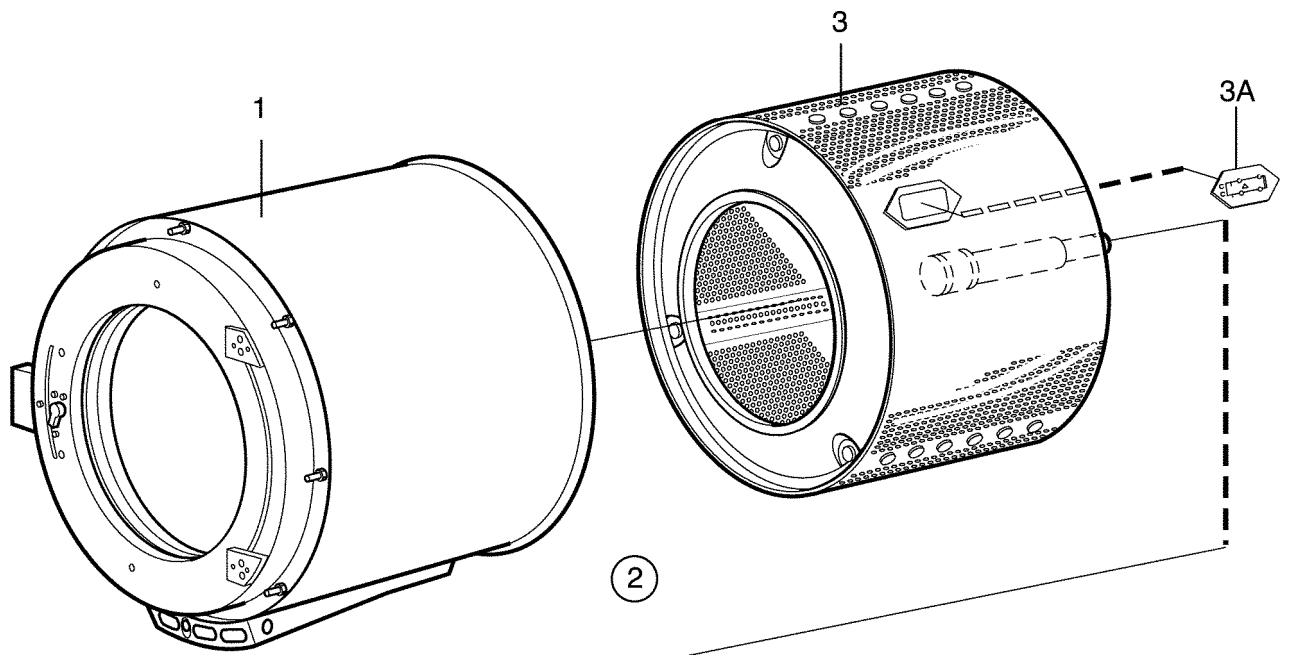

**W575H Compass,W5105H Compass,W5130H Compass,W5180H Compass,W5240H Compass,W5300H Compass**

**Drum, rear gable**

Illustration Issue Month Year  
Illustration Utgåva Månad År

**Trumma,bakgavel**

**500281 1 4 2013**

Item Pos.	Quantity Antal							Art.No Art.nr	Description	Benämning	Info Info	Notes Anmärkning
	W575H Compass											
	W5105H Compass											
	W5130H Compass											
	W5180H Compass											
	W5240H Compass											
	W5300H Compass											
		2						<b>432 1567-01</b>	Tension strap	Spännband		
			2					<b>432 1568-01</b>	Tension strap	Spännband		
				2	2			<b>432 1569-01</b>	Tension strap	Spännband		
<b>20</b>	2	2	2	2	2	2		<b>471 9222-59</b>	Screw	Skruv	M8X140	
<b>21</b>	4	4	4	4	4	4		<b>471 8502-14</b>	Washer	Bricka	BRB 8,4X17	
<b>22</b>	2	2	2	2	2	2		<b>732 2118-01</b>	Locking nut	Låsmutter	M8	
<b>23</b>	Rq	Rq	Rq	Rq	Rq	Rq					Not used	

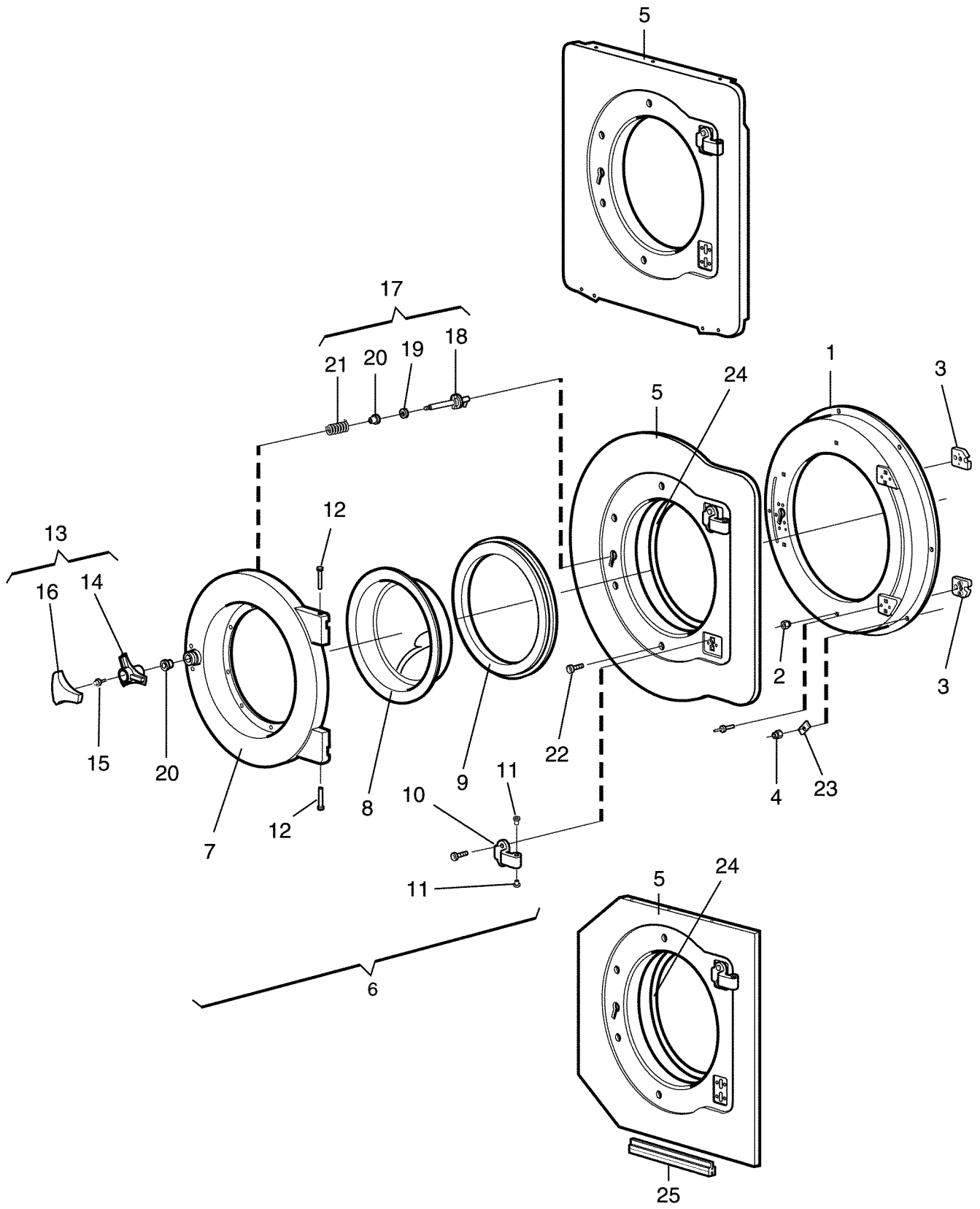

**W575H Compass,W5105H Compass,W5130H Compass,W5180H Compass,W5240H Compass,W5300H Compass**

**Door and hinged joint**

Illustration Issue Month Year  
Illustration Utgåva Månad År

**Lucka och gångled**

**500282 3 12 2014**

Item Pos.	Quantity Antal						Art.No Art.nr	Description	Benämning	Info Info	Notes Anmärkning
	W575H Compass										
	W5105H Compass										
	W5130H Compass										
	W5180H Compass										
	W5240H Compass,W5300H Compass										
1	1						432 1870-01	Support frame	Fästplatta		
		1					432 1871-01	Support frame	Fästplatta		
			1				432 1872-01	Support frame	Fästplatta		
				1			432 1873-01	Support frame	Fästplatta		
					1		432 1874-01	Support frame	Fästplatta		
2	4	4	4	4	4		471 8458-02	Nut	Mutter	M6	
3	2	2	4	4	4		432 1951-01	•Bracket	•Fäste		
4	9	9	11	11	11		471 8404-02	Locking nut	Låsmutter	M6	
5	1						432 1885-03	Trim panel	Dekorplåt		
	1						432 1885-11	Trim panel	Dekorplåt	Stainless	
		1					432 1886-02	Trim panel	Dekorplåt		
		1					432 1886-11	Trim panel	Dekorplåt	Stainless	
			1				432 1887-03	Trim panel	Dekorplåt		
			1				432 1887-04	Trim panel	Dekorplåt	With coin meter	
			1				432 1887-11	Trim panel	Dekorplåt	Stainless	
			1				432 1887-12	Trim panel	Dekorplåt	Stainless With coin meter	
				1	1		432 1888-04	Trim panel	Dekorplåt		
				1	1		432 1888-05	Trim panel	Dekorplåt	With coin meter	
				1	1		432 1888-11	Trim panel	Dekorplåt	Stainless	
				1	1		432 1888-12	Trim panel	Dekorplåt	Stainless With coin meter	
6	1						472 9953-01	Door	Lucka	Complete	
		1					472 9953-02	Door	Lucka	Complete	
			1				472 9953-03	Door	Lucka	Complete	
				1	1		472 9953-04	Door	Lucka	Complete	
				1	1		413 4312-02	Door	Lucka	Complete Lagoon	
7	1						•Door	•Door	•Lucka		
		1					•Door	•Door	•Lucka		
			1				•Door	•Door	•Lucka		
				1	1		•Door	•Door	•Lucka		
8	1						432 1855-01	•Door glass	•Luckglas		
		1					432 1856-01	•Door glass	•Luckglas		
			1				432 1857-01	•Door glass	•Luckglas		
			1				432 1857-02	•Door glass	•Luckglas	Lagoon/ AquaClean	
				1	1		432 1858-01	•Door glass	•Luckglas		
				1	1		432 1858-02	•Door glass	•Luckglas	Lagoon/ AquaClean	
9	1						432 1840-02	•Door gasket	•Luckpackning	Black	
	1						432 1840-03	•Door gasket	•Luckpackning	EPDM Grey	
		1					432 1841-02	•Door gasket	•Luckpackning	Black	
			1				432 1841-04	•Door gasket	•Luckpackning	Silicon Grey	
			1				432 1842-02	•Door gasket	•Luckpackning	Black	
			1				432 1842-03	•Door gasket	•Luckpackning	EPDM Grey	
				1	1		432 1843-02	•Door gasket	•Luckpackning	Black	
				1	1		432 1843-04	•Door gasket	•Luckpackning	Silicon Grey	
10	2	2	2	4	4		432 1950-02	•Hinged joint	•Gångled		
11	4	4	4	8	8		438 4062-01	•Bushing	•Bussning		
12	2	2					432 1961-01	•Pin	•Tapp		
			2	2	2		432 1962-01	•Pin	•Tapp		
13	1	1	1	1	1		472 9957-01	•Knob	•Vred	Complete	
14	1	1	1	1	1		•Knob	••Vred	Complete		
15	1	1	1	1	1		725 2366-61	••Screw	••Skruv	M6SF 6X12	

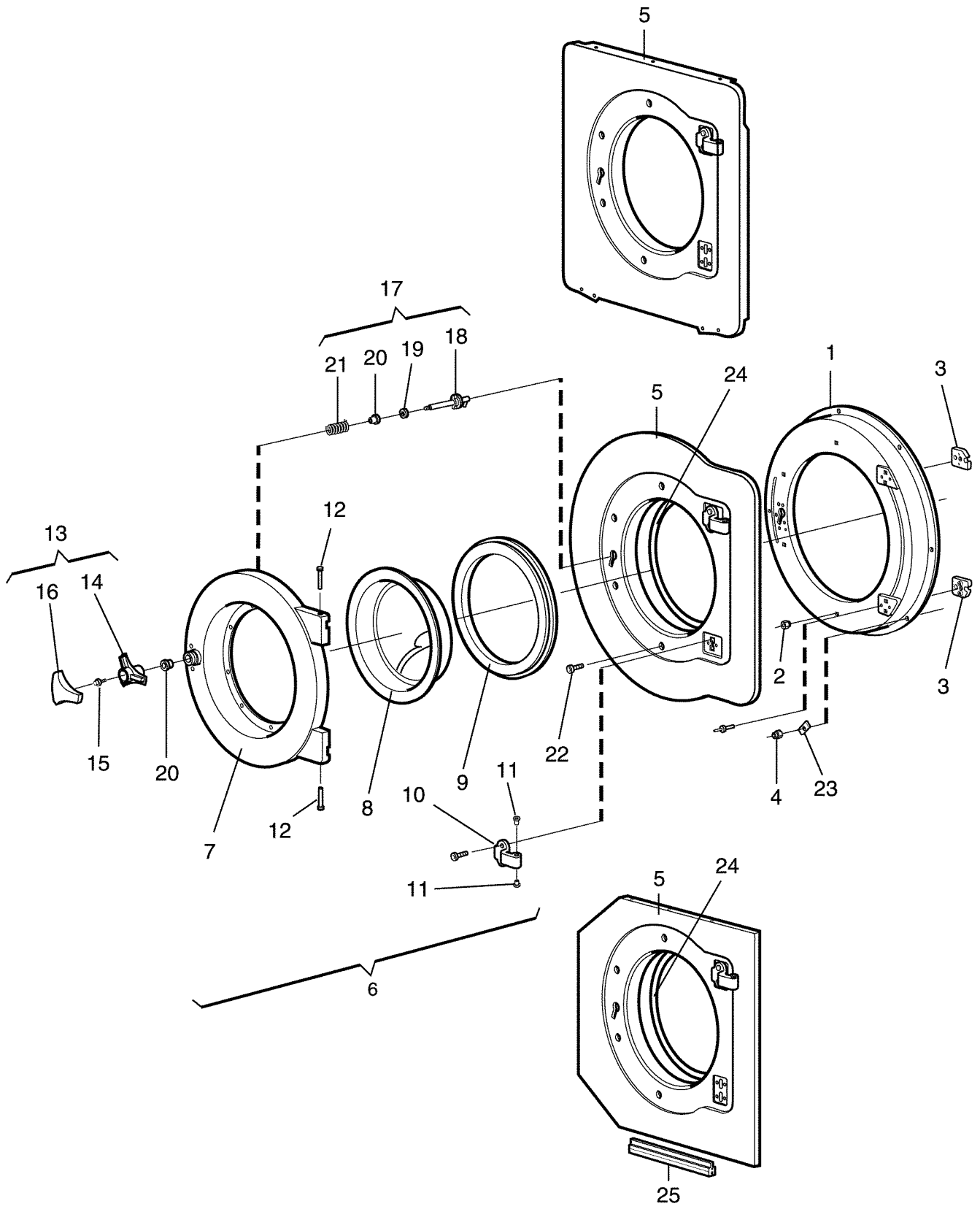

**W575H Compass,W5105H Compass,W5130H Compass,W5180H Compass,W5240H Compass,W5300H Compass**

**Door and hinged joint**

Illustration Issue Month Year  
Illustration Utgåva Månad År

**Lucka och gångled**

**500282 3 12 2014**

Item Pos.	Quantity Antal					Art.No Art.nr	Description	Benämning	Info Info	Notes Anmärkning
	W575H Compass									
	W5105H Compass									
	W5130H Compass									
	W5180H Compass									
	W5240H Compass,W5300H Compass									
16	1	1	1	1	1	432 2270-02	••Knob	••Vred		
17	1	1	1	1	1	472 9920-01	•Lock shaft	•Låsaxel		Complete
18	1	1	1	1	1		••Lock shaft	••Låsaxel		
19	1	1	1	1	1		••Washer	••Bricka		
20	2	2	2	2	2		••Bushing	••Bussning		
21	1	1	1	1	1		••Torsion spring	••Vridfjäder		
22	4	4	8	8	8	471 8344-36	Screw	Skruv		
23			11	11	11	471 8527-01	Spring washer	Fjäderbricka		
24	Rq	Rq	Rq	Rq	Rq					Not used
25	Rq	Rq	Rq	Rq	Rq					Not used

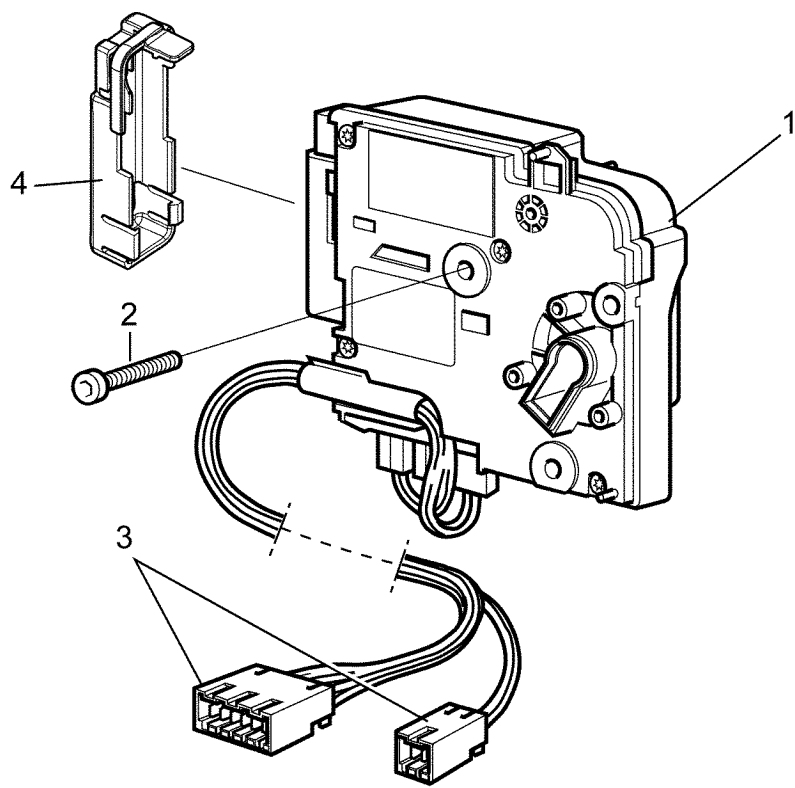



**W575H Compass,W5105H Compass,W5130H Compass,W5180H Compass,W5240H Compass,W5300H Compass**

**Door lock**

Illustration Issue Month Year  
Illustration Utgåva Månad År

**Lucklås**

**500489 1 4 2013**

Item Pos.	Quantity Antal							Art.No Art.nr	Description	Benämning	Info Info	Notes Anmärkning
	W575H Compass											
	W5105H Compass											
	W5130H Compass											
	W5180H Compass											
	W5240H Compass											
	W5300H Compass											
1	1	1	1	1	1	1	1	438 9561-01	Door locking device	Lucklås		Complete M6X25
2	3	3	3	3	3	3	3	471 8342-47	Screw	Skruv		
3	1	1	1	1	1	1	1	432 2905-27	Cable set	Ledningssats		
		1	1	1	1	1	1	432 2905-29	Cable set	Ledningssats		
			1	1	1	1	1	432 2905-31	Cable set	Ledningssats		
				1	1	1	1	432 2905-33	Cable set	Ledningssats		
					1	1	1	432 2905-35	Cable set	Ledningssats		
4	1	1	1	1	1	1	1	432 1982-01	Cover	Skydd		Not used

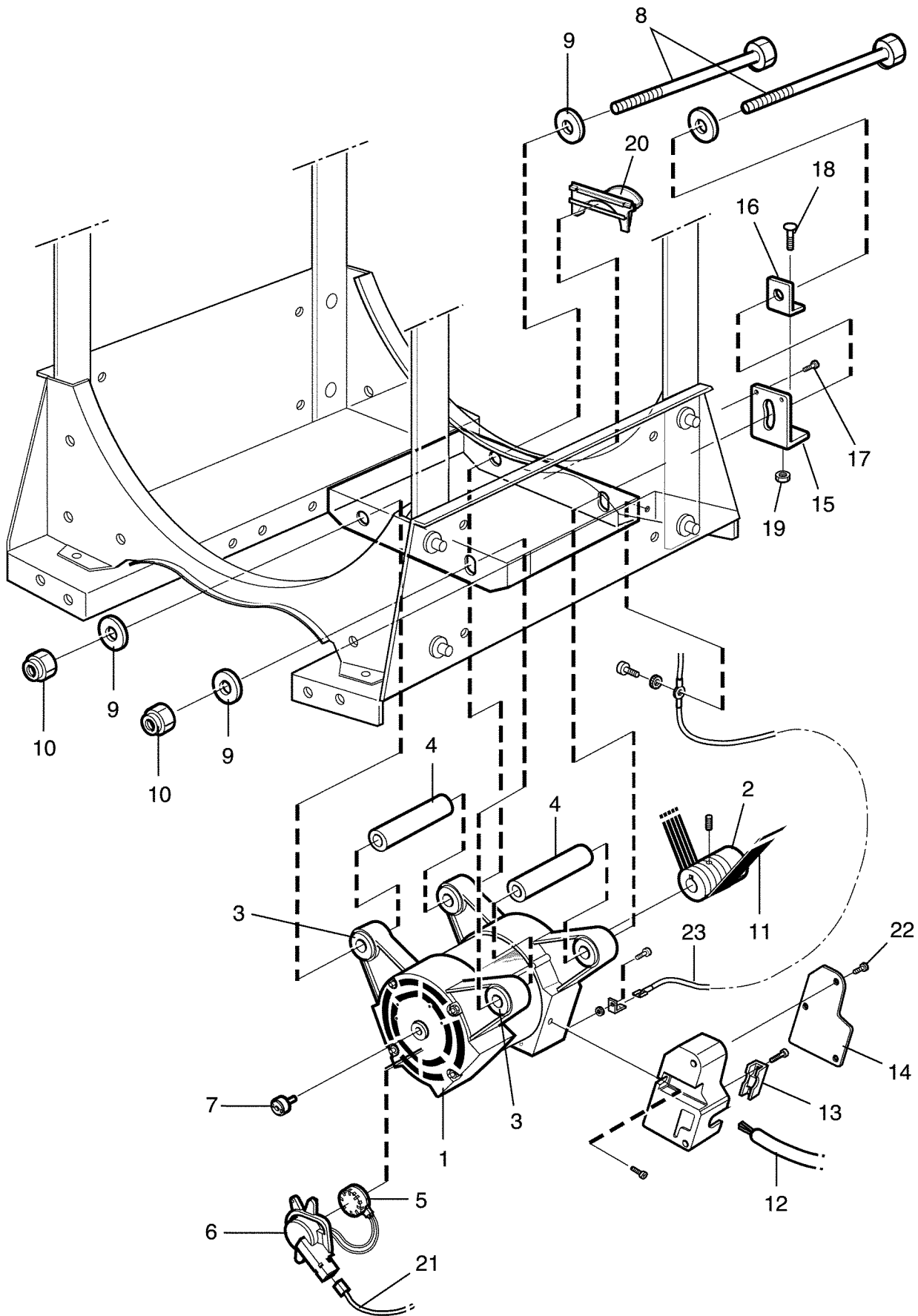

**W575H Compass,W5105H Compass,W5130H Compass,W5180H Compass,W5240H Compass,W5300H Compass**

**Motor**

Illustration Issue Month Year  
Illustration Utgåva Månad År

**Motor**

**500284 3 3 2014**

Item Pos.	Quantity Antal	Art.No Art.nr	Description	Benämning	Info Info	Notes Anmärkning
			W575H Compass			
			W5105H Compass			
			W5130H Compass			
			W5180H Compass			
			W5240H Compass			
			W5300H Compass			
1	1	413 9701-31	Motor	Motor		Complete
	1	438 9702-71	Motor	Motor		Complete
	1	438 9703-21	Motor	Motor		Complete
	1	438 9705-61	Motor	Motor		Complete
	1	438 9705-71	Motor	Motor		Complete
	1	438 9705-21	Motor	Motor		Complete
2	1		•Pulley	•Remskiva		
	1		•Pulley	•Remskiva		
	1		•Pulley	•Remskiva		
	1		•Pulley	•Remskiva		
	1		•Pulley	•Remskiva		
	1		•Pulley	•Remskiva		
3	4	438 8172-01	•Rubber bushing	•Gummibussning		
	4	438 8158-01	•Rubber bushing	•Gummibussning		
	4	438 8158-02	•Rubber bushing	•Gummibussning		
4	2	438 5124-05	•Pipe	•Rör		
	2	432 0641-01	•Pipe	•Rör		
5	1	471 8826-01	•Tacho sensor	•Tachogivare		
6	1	432 1229-01	•Cover	•Kåpa		
7	1	471 8827-01	•Magnet	•Magnet		
8	2	471 8356-14	Screw	Skruv		M8x190
	2	471 8356-05	Screw	Skruv		M12x240
	2	471 8356-06	Screw	Skruv		M12x260
	2	471 8356-08	Screw	Skruv		M12X300
9	4	471 8502-14	Washer	Bricka		BRB 8,4X17
	4	471 8502-10	Washer	Bricka		12x35
	4	471 8502-00	Washer	Bricka		
	4	471 8502-10	Washer	Bricka		12x35
	4	734 1178-01	Washer	Bricka		BRB 13X24
10	2	732 2118-01	Locking nut	Låsmutter		M8
	2	732 2122-01	Locking nut	Låsmutter		M12
11	1	471 7711-13	Ribbed belt	Poly-V-rem		
	1	471 7711-07	Ribbed belt	Poly-V-rem		
	1	471 7711-12	Ribbed belt	Poly-V-rem		
	1	471 7705-02	Ribbed belt	Poly-V-rem		
	1	471 7705-03	Ribbed belt	Poly-V-rem		
12	1	432 2990-01	Cable set	Ledningsatts		
	1	432 2990-02	Cable set	Kabelsats		
	1	432 2991-01	Cable set	Ledningsatts		
13	1	438 9799-02	Clamp	Klamma		
14	1	438 9799-03	Cover	Lock		
15	Rq					Not used
16	Rq	432 1454-01	Belt tensioner	Remspännare		Not used
17	Rq	432 1455-01	Washer	Bricka		
18	Rq	471 8342-23	Screw	Skruv		Not used MRT-TT 5X10
19	Rq	471 8322-03	Screw	Skruv		Not used M8X50
20	Rq	732 2118-01	Locking nut	Låsmutter		Not used M8
	Rq	432 1473-01	Drip guard	Droppskydd		Not used

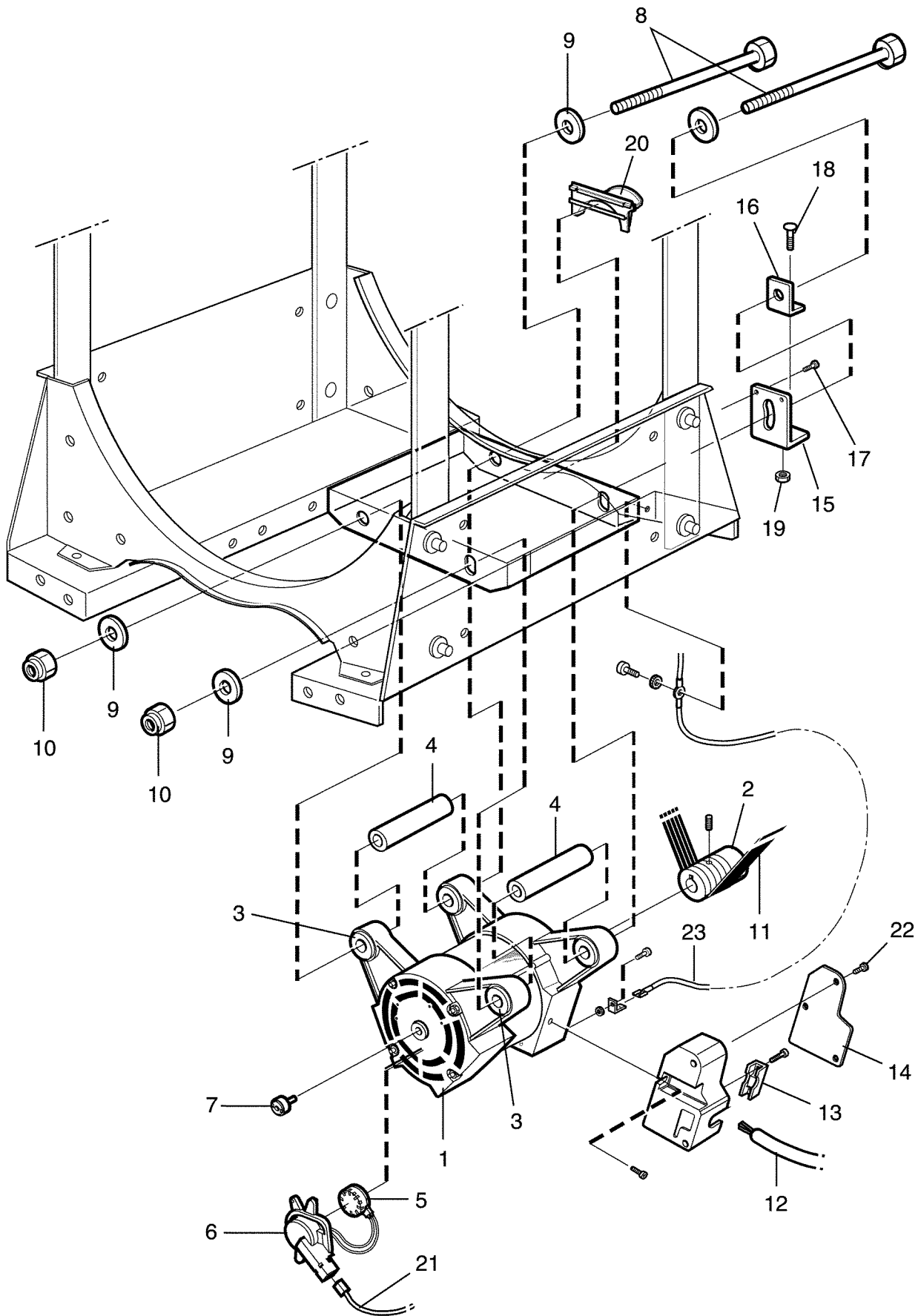

**W575H Compass,W5105H Compass,W5130H Compass,W5180H Compass,W5240H Compass,W5300H Compass**

**Motor**

Illustration Issue Month Year  
Illustration Utgåva Månad År

**Motor**

**500284 3 3 2014**

Item Pos.	Quantity Antal							Art.No Art.nr	Description	Benämning	Info Info	Notes Anmärkning
	W575H Compass											
	W5105H Compass											
	W5130H Compass											
	W5180H Compass											
	W5240H Compass											
	W5300H Compass											
<b>21</b>	1	1	1	1	1	1	1		Cable set	Ledningssats		See illustr. 500489
<b>22</b>	3	3	3	3	3	3	3	<b>471 8342-13</b>	Screw	Skruv		MRT-TT 4X10
<b>23</b>	1	1						<b>432 2983-01</b>	Cable set	Ledningssats		Main switch
			1	1	1	1		<b>432 2983-02</b>	Cable set	Ledningssats		Main switch

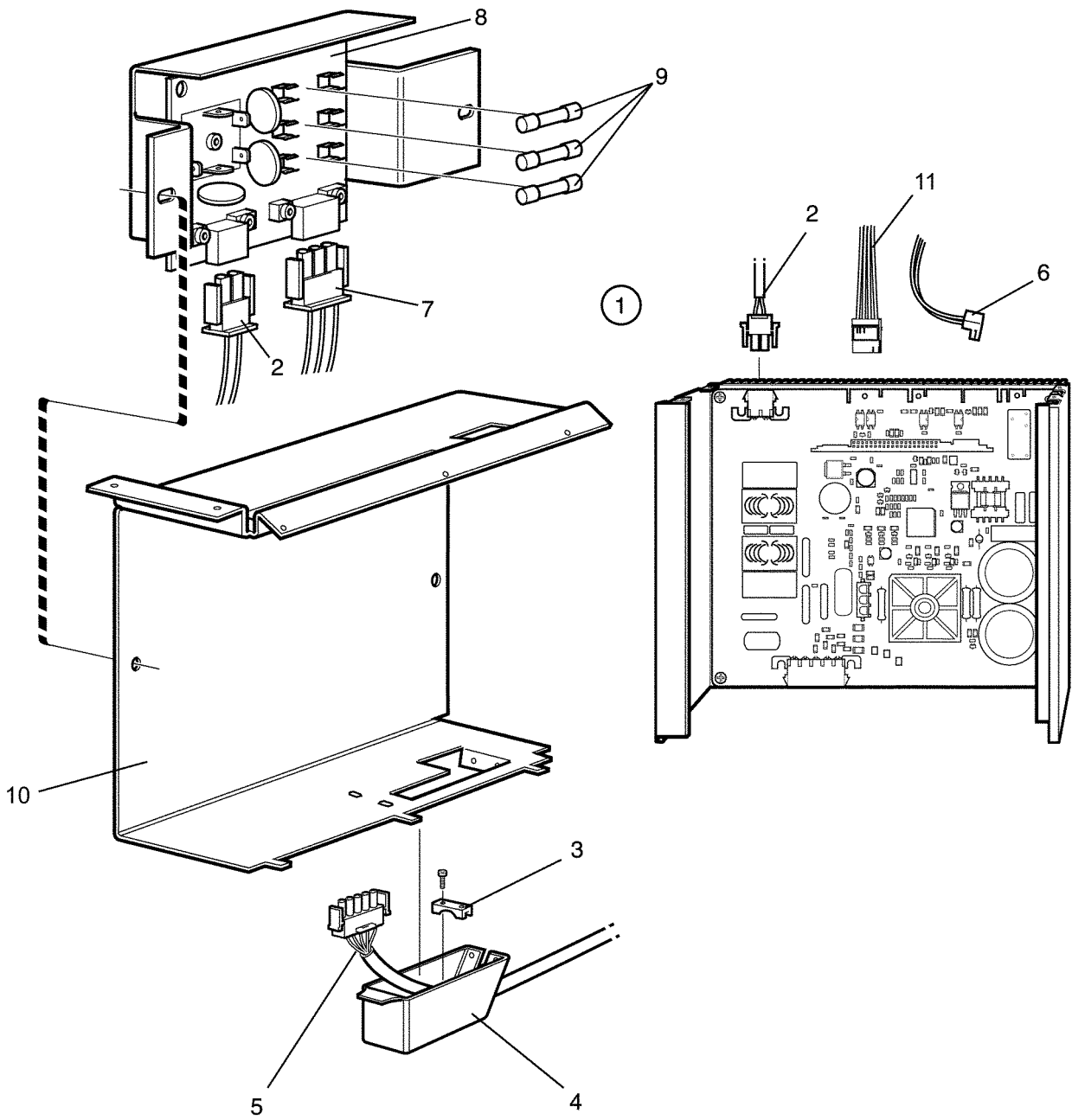

**W575H Compass,W5105H Compass,W5130H Compass,W5180H Compass,W5240H Compass,W5300H Compass**

**Motor control unit**

Illustration Issue Month Year  
Illustration Utgåva Månad År

**Motorstyrningsenhet**

**500285 1 4 2013**

Item Pos.	Quantity Antal		Art.No Art.nr	Description	Benämning	Info Info	Notes Anmärkning
	W575H Compass						
	W5105H Compass						
	W5130H Compass						
	W5180H Compass						
	W5240H Compass						
	W5300H Compass						
1	1	1	472 9929-31	Motor control unit	Motorstyrningsenhet		200-240V
	1	1	472 9929-32	Motor control unit	Motorstyrningsenhet		200-240V Japan/TW
		1	472 9929-41	Motor control unit	Motorstyrningsenhet		200-240V
2	1	1	472 9929-51	Motor control unit	Motorstyrningsenhet		200-240V
	1	1	413 2918-01	•Cable set	•Ledningssats		2-pole 10A
	1	1	413 2918-02	•Cable set	•Ledningssats		2-pole Trafo and choke 10A
	1	1	413 2918-09	•Cable set	•Ledningssats		2-pole Japan/TW 10A
		1	413 2918-03	•Cable set	•Ledningssats		2-pole 16A
		1	413 2918-04	•Cable set	•Ledningssats		2-pole Trafo and choke 16A
		1	413 2918-07	•Cable set	•Ledningssats		2-pole Japan/TW 16A
		1	413 2918-05	•Cable set	•Ledningssats		4-pole 20A
		1	413 2918-06	•Cable set	•Ledningssats		4-pole Trafo and choke 20A
		1	413 2918-08	•Cable set	•Ledningssats		4-pole Japan/TW 20A
3	1	1	438 9799-12	Clamp	Klamma		
4	1	1	438 9799-01	Cover	Kåpa		
5				Cable set	Ledningssats		See motor
6	1		413 3084-10	Cable set	Ledningssats		P-bus-X302
		1	413 3084-21	Cable set	Ledningssats		P-bus-X302
		1	413 3084-22	Cable set	Ledningssats		P-bus-X302
		1	413 3084-23	Cable set	Ledningssats		P-bus-X302
		1	413 3084-24	Cable set	Ledningssats		P-bus-X302
7	1	1	432 2961-01	Cable set	Ledningssats		3AC
8	1	1	438 8774-02	Printed circuit board	Kretskort		
9	3	3	471 8768-02	Fuse	Säkring		15A
10	1	1	472 9938-01	Cover	Skydd		
		1	472 9938-02	Cover	Skydd		
		1	472 9938-03	Cover	Skydd		
11	1		413 3276-07	Cable set	Ledningssats		M-COM
		1	413 3276-08	Cable set	Ledningssats		M-COM
		1	413 3276-11	Cable set	Ledningssats		M-COM
		1	413 3276-09	Cable set	Ledningssats		M-COM

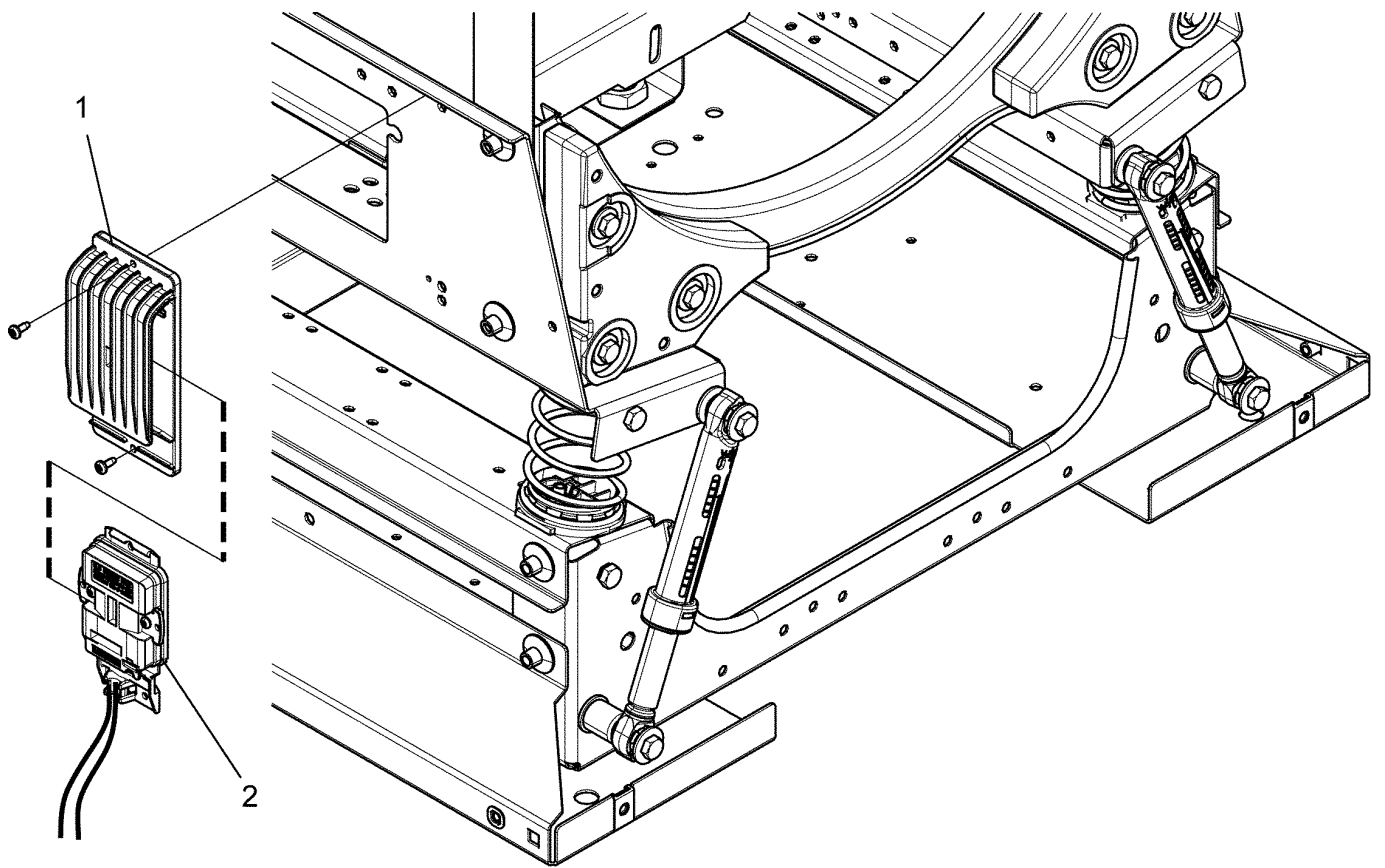



**W575H Compass,W5105H Compass,W5130H Compass,W5180H Compass,W5240H Compass,W5300H Compass**

**Power balance unit**

Illustration Issue Month Year  
Illustration Utgåva Månad År

**Obalanskontroll enhet**

**500361 2 8 2013**

Item Pos.	Qua. Ant.	Art.No Art.nr	Description	Benämning	Info Info	Notes Anmärkning
<b>1</b>	1	<b>413 1221-01</b>	Bracket	Hållare		
<b>2</b>	1	<b>432 6937-01</b>	I/O module	I/O modul		Type 6

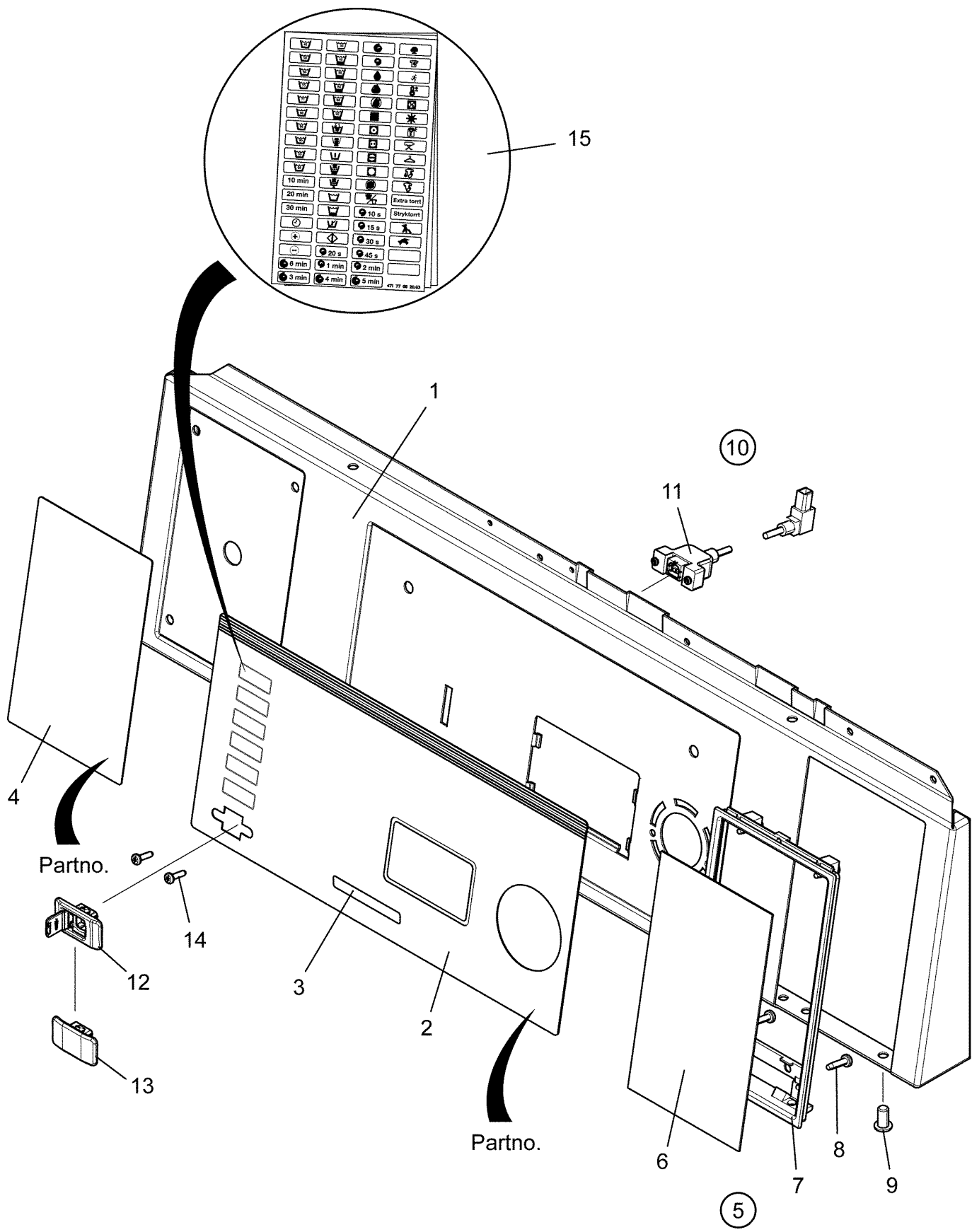

**W575H Compass,W5105H Compass**

**Control panel**

**Manöverpanel**

Illustration Issue Month Year  
Illustration Utgåva Månad År  
**500371 1 4 2013**

Item Pos.	Quantity Antal	Art.No Art.nr	Description	Benämning	Info Info	Notes Anmärkning
			W575H Compass			
			W5105H Compass			
1	1	432 2361-01	Front panel	Frontpanel		
2	1	432 2362-01	Front panel	Frontpanel		
			Panel sign	Panelskylt		Check sign for correct part number
	1	472 5797-10	Panel sign	Panelskylt		
	1	472 5797-12	Panel sign	Panelskylt		
	1	472 5797-13	Panel sign	Panelskylt		
	1	472 5797-30	Panel sign	Panelskylt		
	1	472 5797-35	Panel sign	Panelskylt		
	1	472 5797-40	Panel sign	Panelskylt		
	1	472 5797-80	Panel sign	Panelskylt		
	1	472 5797-50	Panel sign	Panelskylt		Coin Wascomat
	1	472 5797-51	Panel sign	Panelskylt		OPL Wascomat
3	1	413 2621-01	Type plate	Typskylt		W575H
	1	413 2621-02	Type plate	Typskylt		W575H LE
	1	413 2623-02	Type plate	Typskylt		W575H Wool
	1	413 2631-16	Type plate	Typskylt		EX718co
	1	413 2631-18	Type plate	Typskylt		EX718cc
	1	413 2623-01	Type plate	Typskylt		W5105H
	1	413 2631-19	Type plate	Typskylt		EX725co
	1	413 2631-21	Type plate	Typskylt		EX725cc
4			Instruction plate	Instruktionsskylt		Check sign for correct part number
	1	432 2653-10	Instruction plate	Instruktionsskylt		
	1	432 2653-11	Instruction plate	Instruktionsskylt		
	1	432 2653-12	Instruction plate	Instruktionsskylt		
	1	432 2653-14	Instruction plate	Instruktionsskylt		
	1	432 2653-15	Instruction plate	Instruktionsskylt		
	1	432 2653-30	Instruction plate	Instruktionsskylt		
	1	432 2653-31	Instruction plate	Instruktionsskylt		
	1	432 2653-80	Instruction plate	Instruktionsskylt		
5	1	472 9955-07	Cover plates	Täckplåtar		Kit compl.
6	1		•Cover plate	•Täckplåt		
7	1		•Frame	•Ram		
8	4		•Screw	•Skruv		
9	2		•Screw	•Skruv		
10	1	472 9956-03	Cable	Kabel		USB Kit
11	1	413 2936-01	•Cable	•Kabel		USB
12	1	472 9956-01	•Cover	•Skydd		Kit
13	1	472 9956-02	•Blind plug	•Blindpropp		Kit
14	2	471 8340-13	Screw	Skruv		RTS 3,5X13
15	1	472 9940-02	Stickers kit	Etikett sats		
	1	472 9940-04	Stickers kit	Etikett sats		Japan

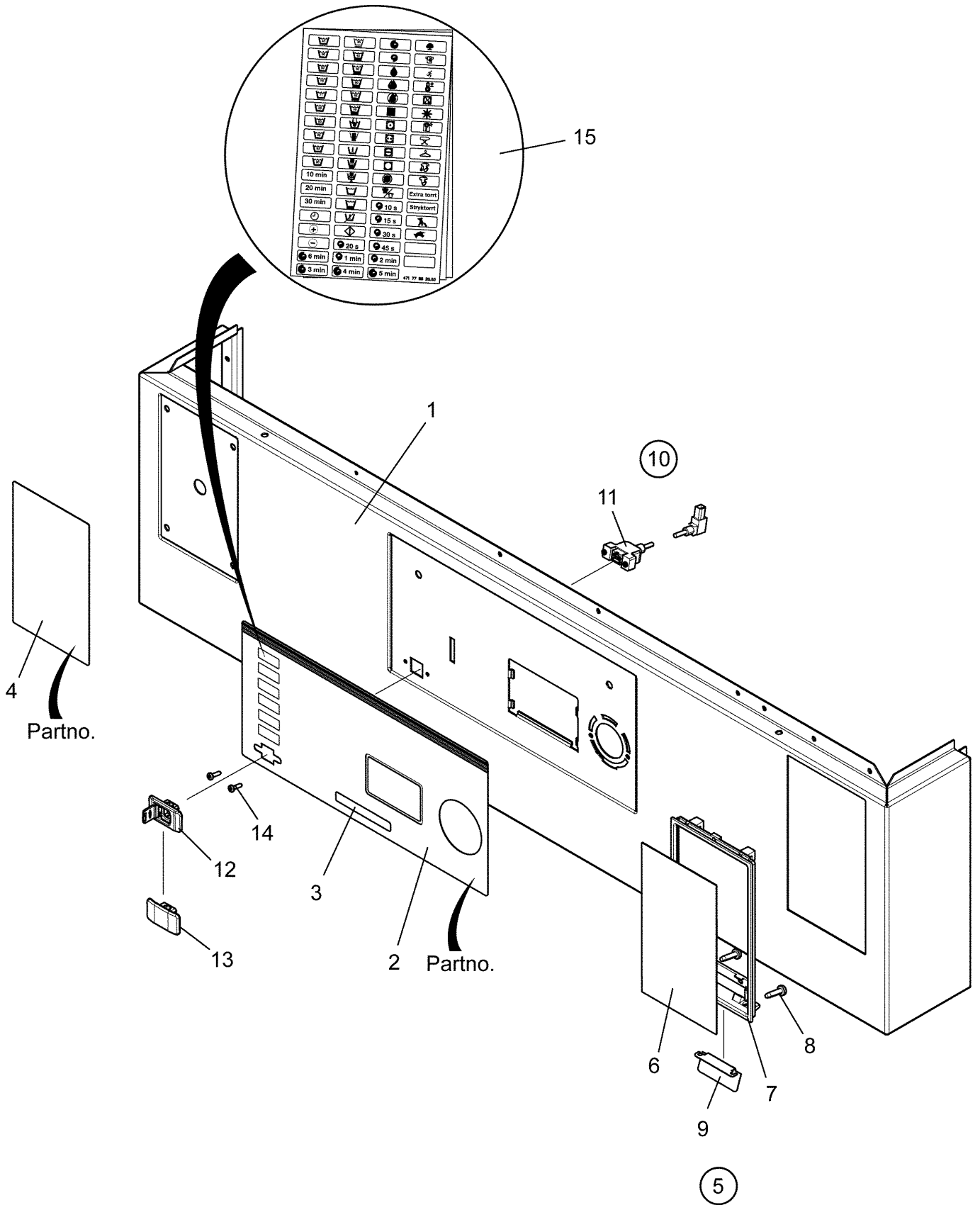

**W5130H Compass,W5180H Compass,W5240H Compass,W5300H Compass**

**Control panel**

Illustration Issue Month Year  
Illustration Utgåva Månad År

**Manöverpanel**

**500372 1 4 2013**

Item Pos.	Quantity Antal				Art.No Art.nr	Description	Benämning	Info Info	Notes Anmärkning
	W5130H Compass								
	W5180H Compass								
	W5240H Compass								
	W5300H Compass								
1	1				432 2366-01	Front panel	Frontpanel		
		1			432 2367-01	Front panel	Frontpanel		
2			1	1	432 2368-01	Front panel	Frontpanel		Check sign for correct part number
						Panel sign	Panelskylt		
	1	1	1	1	472 5797-10	Panel sign	Panelskylt		
	1	1	1	1	472 5797-12	Panel sign	Panelskylt		
	1	1	1	1	472 5797-13	Panel sign	Panelskylt		
	1	1	1	1	472 5797-30	Panel sign	Panelskylt		
	1	1	1	1	472 5797-35	Panel sign	Panelskylt		
	1	1	1	1	472 5797-40	Panel sign	Panelskylt		
	1	1	1	1	472 5797-80	Panel sign	Panelskylt		
	1	1	1	1	472 5797-50	Panel sign	Panelskylt		
	1	1	1	1	472 5797-51	Panel sign	Panelskylt		
3	1				413 2624-01	Type plate	Typskylt		Coin Wascomat OPL Wascomat W5130H W5130H Wool EX730co EX730cc W5180H W5180H Wool EX745co EX745cc W5240H W5240H Wool EX760co EX760cc W5300H W5300H Wool EX777co EX777cc
	1				413 2624-02	Type plate	Typskylt		
	1				413 2631-22	Type plate	Typskylt		
	1				413 2631-24	Type plate	Typskylt		
		1			413 2625-04	Type plate	Typskylt		
		1			413 2625-02	Type plate	Typskylt		
		1			413 2631-30	Type plate	Typskylt		
		1			413 2631-31	Type plate	Typskylt		
			1		413 2627-01	Type plate	Typskylt		
			1		413 2627-02	Type plate	Typskylt		
			1		413 2631-38	Type plate	Typskylt		
			1		413 2631-39	Type plate	Typskylt		
				1	413 2628-01	Type plate	Typskylt		
				1	413 2628-02	Type plate	Typskylt		
				1	413 2631-46	Type plate	Typskylt		
4				1	413 2631-47	Type plate	Typskylt		
						Instruction plate	Instruktionsskylt		Check sign for correct part number
	1	1	1	1	432 2653-10	Instruction plate	Instruktionsskylt		
	1	1	1	1	432 2653-11	Instruction plate	Instruktionsskylt		
	1	1	1	1	432 2653-12	Instruction plate	Instruktionsskylt		
	1	1	1	1	432 2653-14	Instruction plate	Instruktionsskylt		
	1	1	1	1	432 2653-15	Instruction plate	Instruktionsskylt		
	1	1	1	1	432 2653-30	Instruction plate	Instruktionsskylt		
	1	1	1	1	432 2653-31	Instruction plate	Instruktionsskylt		
	1	1	1	1	432 2653-80	Instruction plate	Instruktionsskylt		
5	1	1	1	1	472 9955-07	Cover plates	Täckplåtar		
6	1	1	1	1		•Cover plate	•Täckplåt	Kit compl.	
7	1	1	1	1		•Frame	•Ram		
8	4	4	4	4		•Screw	•Skruv		
9	1	1	1	1		•Mounting plate	•Monteringsplåt		
10	1	1	1	1	472 9956-03	Cable	Kabel	USB Kit	
11	1	1	1	1	413 2936-01	•Cable	•Kabel		
12	1	1	1	1	472 9956-01	•Cover	•Skydd	Kit	
13	1	1	1	1	472 9956-02	•Blind plug	•Blindpropp		
14	2	2	2	2	471 8340-13	Screw	Skruv	RTS 3,5X13	
15	1	1	1	1	472 9940-02	Stickers kit	Etikett sats		
	1	1	1	1	472 9940-04	Stickers kit	Etikett sats	Japan	

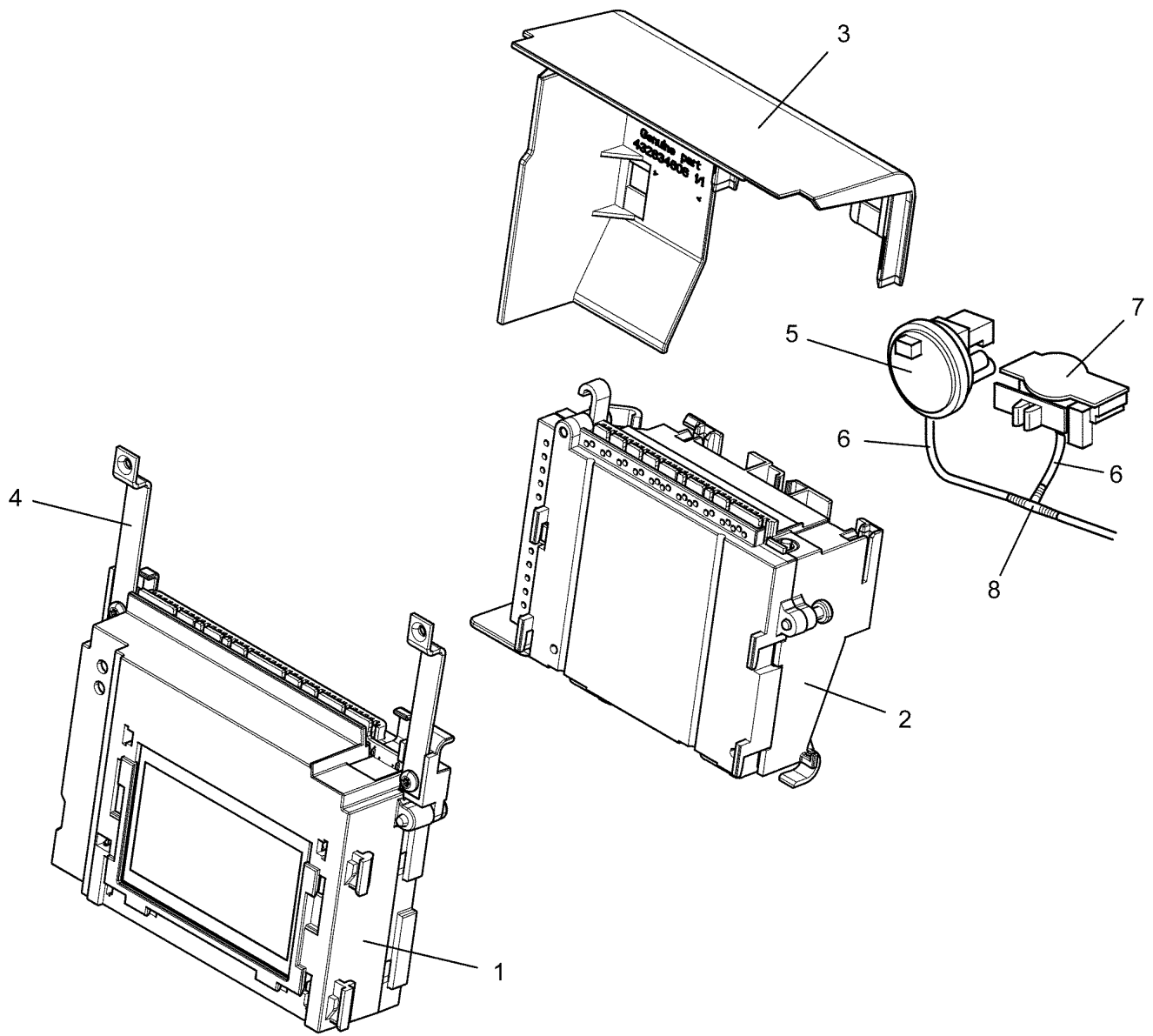
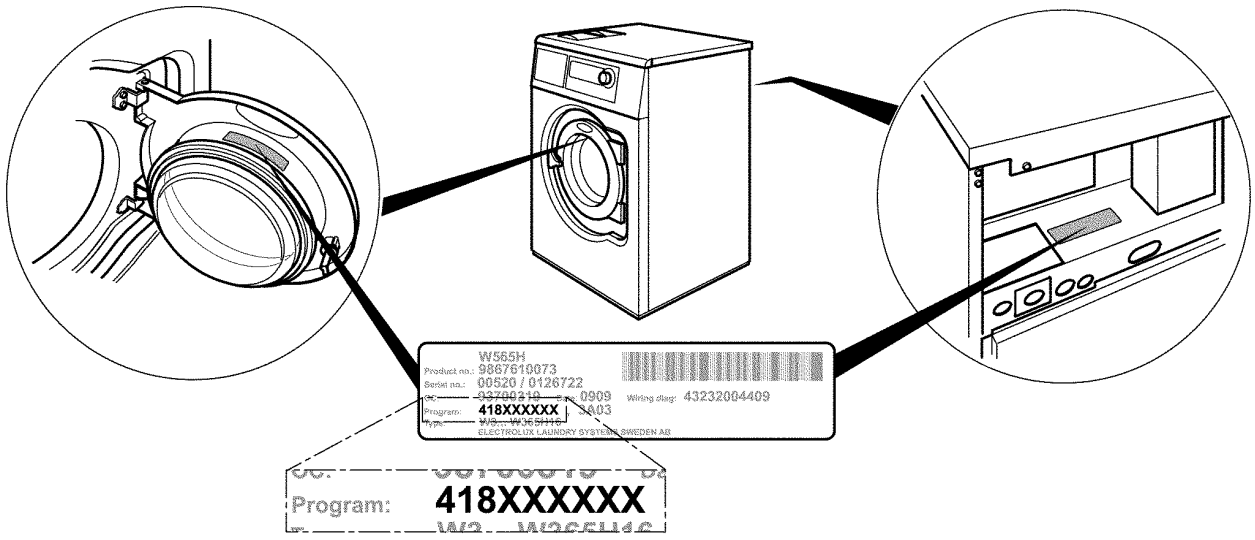

**W575H Compass,W5105H Compass,W5130H Compass,W5180H Compass,W5240H Compass,W5300H Compass**

**CPU**

Illustration Issue Month Year  
Illustration Utgåva Månad År

**CPU**

**500231 1 4 2013**

Item Pos.	Qua. Ant.	Art.No Art.nr	Description	Benämning	Info Info	Notes Anmärkning
<b>1</b>	1	<b>432 6820-02</b>	CPU	CPU		Without software. Software available on website
<b>2</b>	1	<b>432 6809-01</b>	I/O module	I/O modul		Type 10
<b>3</b>	1	<b>432 6346-06</b>	Cover	Skydd		
<b>4</b>	2	<b>432 6353-02</b>	Ground terminal	Jordanslutning		
<b>5</b>	1	<b>471 8861-03</b>	Level guard	Nivåvakt		
<b>6</b>	2	<b>471 2442-41</b>	Hose	Slang		L=70
<b>7</b>	1	<b>471 8863-02</b>	Level guard	Nivåvakt		
<b>8</b>	1	<b>471 2265-69</b>	T-pipe	T-rör		

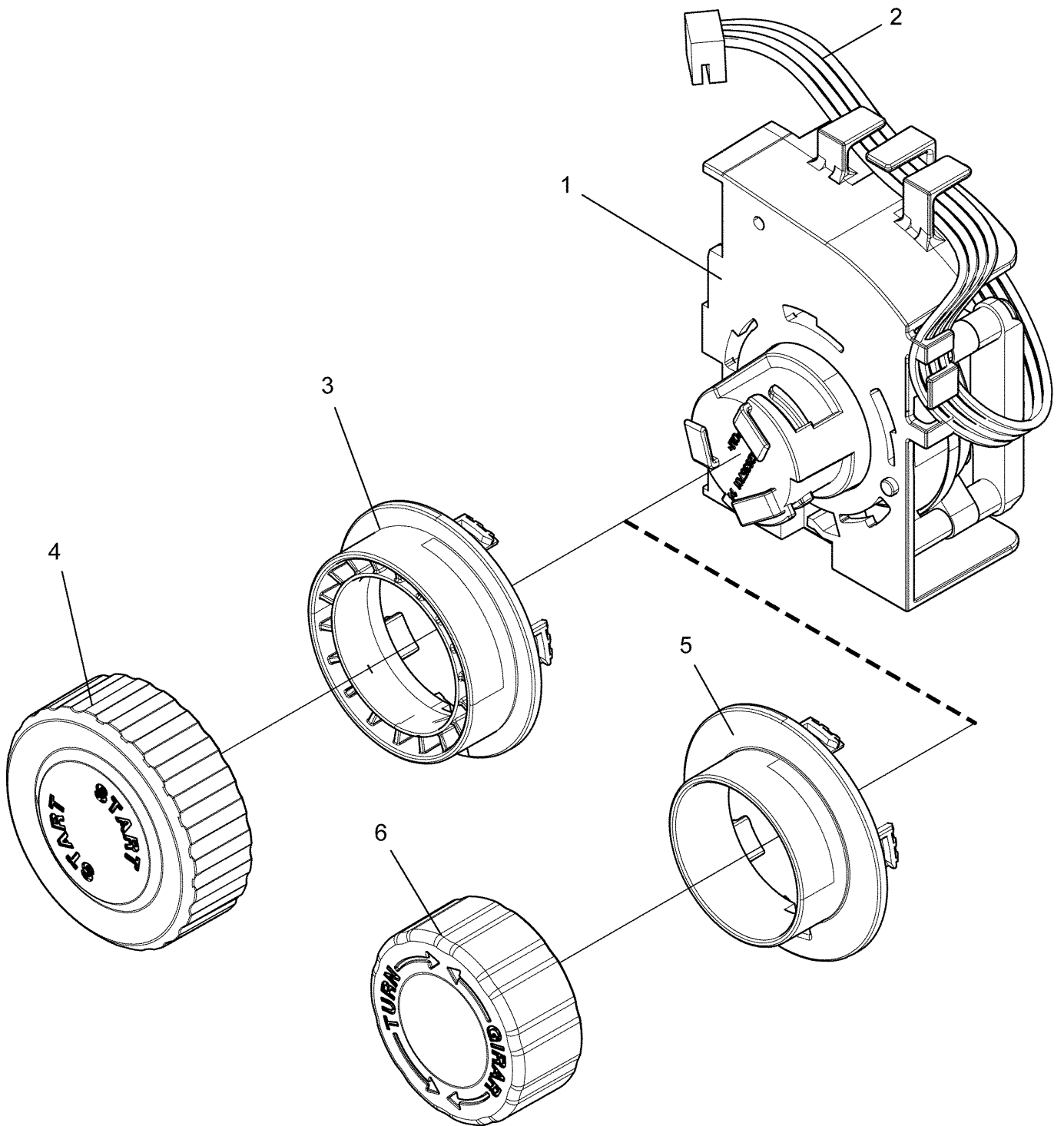



**W575H Compass,W5105H Compass,W5130H Compass,W5180H Compass,W5240H Compass,W5300H Compass**

**Program selector**

Illustration Issue Month Year  
Illustration Utgåva Månad År

**Programväljare**

**500323 1 4 2013**

Item Pos.	Qua. Ant.	Art.No Art.nr	Description	Benämning	Info Info	Notes Anmärkning
<b>1</b>	1	<b>432 6810-02</b>	Program selector	Programväljare		Complete
<b>2</b>	1	<b>413 3274-20</b>	Cable set	Ledningssats		4-pole
<b>3</b>	1	<b>432 6356-01</b>	Cover	Lock		
<b>4</b>	1	<b>432 6355-02</b>	Knob	Vred		
<b>5</b>	1	<b>432 6373-01</b>	Cover	Lock		Wascomat
<b>6</b>	1	<b>432 6372-01</b>	Knob	Vred		Wascomat

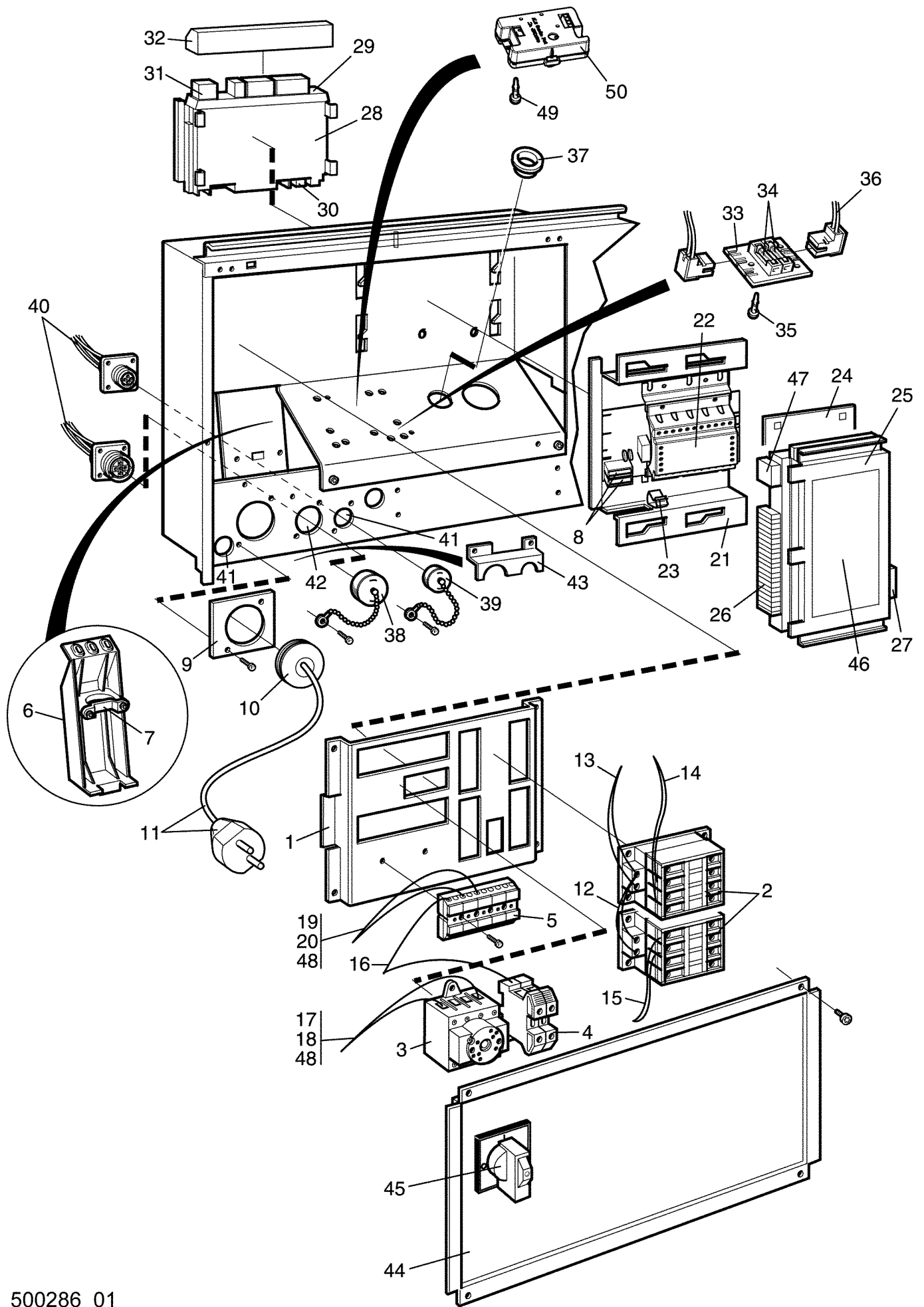

**W575H Compass,W5105H Compass,W5130H Compass,W5180H Compass,W5240H Compass,W5300H Compass**

**Electric components connection**

Illustration Issue Month Year  
Illustration Utgåva Månad År

**Eldetaljer anslutning**

**500286 1 4 2013**

Item Pos.	Quantity Antal							Art.No Art.nr	Description	Benämning	Info Info	Notes Anmärkning
	W575H Compass											
	W5105H Compass											
	W5130H Compass											
	W5180H Compass											
	W5240H Compass											
	W5300H Compass											
1	1	1	1	1	1	1	1	432 2154-01	Mounting plate	Monteringsplåt		
2	1	Rq	Rq	Rq	Rq	Rq	Rq	438 9636-22	Contactora	Kontaktor	50Hz	
	1	Rq	Rq	Rq	Rq	Rq	Rq	438 9636-23	Contactora	Kontaktor	60Hz	
	1	Rq	Rq	Rq	Rq	Rq	Rq	438 9636-24	Contactora	Kontaktor	50/60Hz	
	1	1	1	1	1	1	1	438 9636-92	Contactora	Kontaktor	50Hz	
	1	1	1	1	1	1	1	438 9636-93	Contactora	Kontaktor	60Hz	
	Rq	Rq	Rq	Rq	Rq	Rq	Rq	438 9636-94	Contactora	Kontaktor	50/60Hz	
3	Rq	Rq	Rq	Rq	Rq	Rq	Rq	438 9678-01	Main switch	Huvudbrytare	3-pole, 32A	
	Rq	Rq	Rq	Rq	Rq	Rq	Rq	438 9678-02	Main switch	Huvudbrytare	3-pole, 40A	
	Rq	Rq	Rq	Rq	Rq	Rq	Rq	438 9678-03	Main switch	Huvudbrytare	3-pole, 63A	
	Rq	Rq	Rq	Rq	Rq	Rq	Rq	438 9678-04	Main switch	Huvudbrytare	3-pole, 80A	
	Rq	Rq	Rq	Rq	Rq	Rq	Rq	438 9678-11	Main switch	Huvudbrytare	4-pole, 32A	
	Rq	Rq	Rq	Rq	Rq	Rq	Rq	438 9678-12	Main switch	Huvudbrytare	4-pole, 40A	
	Rq	Rq	Rq	Rq	Rq	Rq	Rq	438 9678-13	Main switch	Huvudbrytare	4-pole, 63A	
	Rq	Rq	Rq	Rq	Rq	Rq	Rq	438 9678-14	Main switch	Huvudbrytare	4-pole, 80A	
4	2	2	2	2	2	2	2	471 8767-01	Block	Plint	SL10	
	2	2	2	2	2	2	2	471 8767-02	Block	Plint	SL16	
5	1	1	1	1	1	1	1	471 8783-01	Block	Plint	5-pole	
	1	1	1	1	1	1	1	471 8783-03	Block	Plint	3-pole	
	1	1	1	1	1	1	1	471 8783-04	Block	Plint	4-pole	
6	1	1	1	1	1	1	1	432 2258-01	Plate	Plåt		
	1	1	1	1	1	1	1	432 2214-01	Cable clamp	Kabelklämma	PLASTIC	
7	1	1	1	1	1	1	1	471 7859-16	Clamp	Klämma	Upper part	
8	2	2	2	2	2	2	2	471 8750-16	Fuse	Säkring	3,15A	
9	1	1	1	1	1	1	1	432 2199-01	Plate	Plåt	Ø21	
	1	1	1	1	1	1	1	432 2199-03	Plate	Plåt	Ø26	
	1	1	1	1	1	1	1	432 2199-05	Plate	Plåt	Ø33	
10	1	1	1	1	1	1	1	438 8720-01	Grommet	Genomföring	M25	
	1	1	1	1	1	1	1	438 8720-02	Grommet	Genomföring	M32	
	1	1	1	1	1	1	1	438 8720-03	Grommet	Kabelgenomföring	M40	
11	1	1	1	1	1	1	1	490 4440-17	Cable	Kabel		
12	1	1	1	1	1	1	1	432 2984-01	Cable set	Ledningssats	Not used	
13	1	1	1	1	1	1	1	413 3182-02	Cable set	Ledningssats	Heating	
	1	1	1	1	1	1	1	413 2915-02	Cable set	Ledningssats	MOP Heating	
14	Rq	Rq	Rq	Rq	Rq	Rq	Rq	432 2954-03	Cable set	Ledningssats		
15	Rq	Rq	Rq	Rq	Rq	Rq	Rq	432 2954-13	Cable set	Ledningssats		
	Rq	Rq	Rq	Rq	Rq	Rq	Rq	432 2954-14	Cable set	Ledningssats	MOP	
16	1	1	1	1	1	1	1	432 2983-03	Cable set	Ledningssats		
	1	1	1	1	1	1	1	432 2983-04	Cable set	Ledningssats		
17	1	1	1	1	1	1	1	432 3092-86	Cable set	Ledningssats		
18	1	1	1	1	1	1	1	432 3106-01	Cable set	Ledningssats	Trafo	
19	1	1	1	1	1	1	1	413 3082-35	Cable set	Ledningssats		
20	1	1	1	1	1	1	1	413 2905-02	Cable set	Ledningssats	Trafo	
21	1	1	1	1	1	1	1	432 2257-01	Mounting plate	Monteringsplåt		
22	1	1	1	1	1	1	1	432 6805-07	Power supply unit	Strömförsörjningsenhet	3,15A	
23	1	1	1	1	1	1	1	432 6320-01	Clamp	Klamma		
24	1	1	1	1	1	1	1	432 2256-01	Plate	Plåt		
25	1	1	1	1	1	1	1	432 6930-03	I/O module	I/O modul	Type 2	
26	Rq	Rq	Rq	Rq	Rq	Rq	Rq	438 8701-01	Multistik	Kantanslutning		
	Rq	Rq	Rq	Rq	Rq	Rq	Rq	438 8701-03	Multistik	Kantanslutning		
27	1	1	1	1	1	1	1	413 3274-01	Cable set	Ledningssats		
28	1	1	1	1	1	1	1	432 6903-03	I/O module	I/O modul	Type 1	

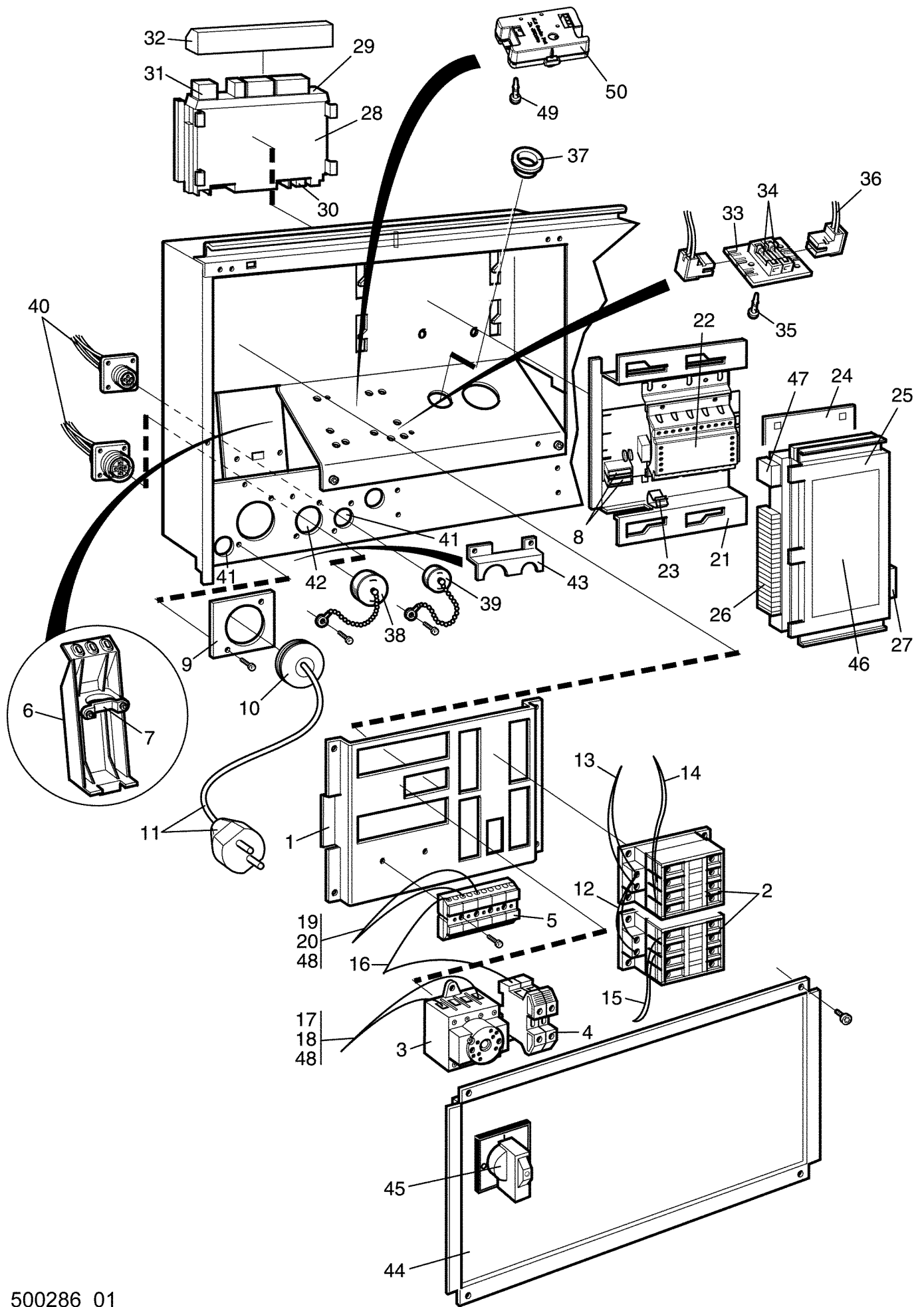

**W575H Compass,W5105H Compass,W5130H Compass,W5180H Compass,W5240H Compass,W5300H Compass**

**Electric components connection**

Illustration Issue Month Year  
Illustration Utgåva Månad År

**Eldetaljer anslutning**

**500286 1 4 2013**

Item Pos.	Quantity Antal						Art.No Art.nr	Description	Benämning	Info Info	Notes Anmärkning
	W575H Compass										
	W5105H Compass										
	W5130H Compass										
	W5180H Compass										
	W5240H Compass										
	W5300H Compass										
	1	1	1	1	1	1	<b>432 6903-02</b>	I/O module	I/O modul		Type 11
	1	1	1	1	1	1	<b>432 6933-03</b>	I/O module	I/O modul		Type 3
<b>29</b>								Sign	Skylt		
<b>30</b>	1	1	1	1	1	1	<b>413 3274-32</b>	Cable set	Ledningssats		4-pole
<b>31</b>	1	1	1	1	1	1	<b>413 3084-25</b>	Cable set	Ledningssats		4-pole
<b>32</b>	1	1	1	1	1	1	<b>432 6323-01</b>	Cover	Skydd		
<b>33</b>	1	1	1	1	1	1	<b>438 8797-02</b>	Printed circuit board	Kretskort		
<b>34</b>	2	2	2	2	2	2	<b>471 8750-11</b>	•Fuse	•Säkring		1,25A
<b>35</b>	3	3	3	3	3	3	<b>471 7960-02</b>	Support	Stöd		
<b>36</b>	1	1	1	1	1	1	<b>413 3082-05</b>	Cable set	Ledningssats		
<b>37</b>	1	1	1	1	1	1	<b>471 7984-01</b>	Grommet	Genomföring		
<b>38</b>	1	1	1	1	1	1	<b>438 7950-02</b>	Cover washer	Täckbricka		14-pole
<b>39</b>	1	1	1	1	1	1	<b>438 7950-01</b>	Cover washer	Täckbricka		4-pole
<b>40</b>	1	1	1	1	1	1	<b>413 2946-01</b>	Cable set	Ledningssats		
<b>41</b>	2	2	2	2	2	2	<b>471 7977-03</b>	Cover plug	Täckpropp		
<b>42</b>	1	1	1	1	1	1	<b>471 7977-04</b>	Cover plug	Täckpropp		
<b>43</b>	1	1	1	1	1	1	<b>432 1220-01</b>	Cover	Skydd		
<b>44</b>	1	1	1	1	1	1	<b>432 3604-01</b>	Cover	Lock		With hole
	1	1	1	1	1	1	<b>432 3604-02</b>	Cover	Lock		Without hole
<b>45</b>	1	1	1	1	1	1	<b>471 9678-94</b>	Knob	Vred		
<b>46</b>	1	1	1	1	1	1	<b>471 4673-93</b>	Sign	Skylt		I/O-card type 2
<b>47</b>	1	1	1	1	1	1	<b>413 3084-02</b>	Cable set	Ledningssats		4-pole P-bus
<b>48</b>	1	1					<b>413 2918-01</b>	Cable set	Ledningssats		2-pole 10A
	1	1					<b>413 2918-02</b>	Cable set	Ledningssats		2-pole Trafo and choke 10A
			1				<b>413 2918-03</b>	Cable set	Ledningssats		2-pole 16A
			1				<b>413 2918-04</b>	Cable set	Ledningssats		2-pole Trafo and choke 16A
				1	1	1	<b>413 2918-05</b>	Cable set	Ledningssats		4-pole 20A
				1	1	1	<b>413 2918-06</b>	Cable set	Ledningssats		4-pole Trafo and choke 20A
<b>49</b>	4	4	4	4	4	4	<b>471 7958-02</b>	Support	Stöd		
<b>50</b>	1	1	1	1	1	1	<b>413 1226-01</b>	Printed circuit board	Kretskort		ELS Network interface



**W575H Compass,W5105H Compass,W5130H Compass,W5180H Compass,W5240H Compass,W5300H Compass**

**Drain valve and hoses**

Illustration Issue Month Year  
Illustration Utgåva Månad År

**Avloppsventil och slangar**

**500287 3 3 2014**

Item Pos.	Quantity Antal							Art.No Art.nr	Description	Benämning	Info Info	Notes Anmärkning
	W575H Compass											
	W5105H Compass											
	W5130H Compass											
	W5180H Compass											
	W5240H Compass											
	W5300H Compass											
1	1	1	1	1	1	1	1	432 2502-01	Drain valve	Avloppsventil		
2	1	1	1					471 8139-11	Hose	Slang	L=1900	
				1	1	1		471 8139-16	Hose	Slang	L=2250	
3	1	1	1	1	1	1	1	471 8243-07	Solenoid valve	Magnetventil	230V 50Hz	
	1	1	1	1	1	1	1	471 8243-08	Solenoid valve	Magnetventil	208-240V 60Hz	
	1	1	1	1	1	1	1	471 8243-09	Solenoid valve	Magnetventil	120V 60Hz	
	1	1	1	1	1	1	1	471 8243-10	Solenoid valve	Magnetventil	230V 50/60Hz	
											Japan	
4	1	1	1	1	1	1	1	438 8102-06	Hose	Slang	L=330	
5	1	1	1	1	1	1	1	471 8139-01	Hose	Slang	L=330	
6	1	1						432 2515-01	Hose	Slang		
			1	1	1	1		432 2516-02	Hose	Slang		
7	1	1						413 5004-01	Drain pipe connection	Avloppsstos		
			1	1	1	1		432 2511-01	Drain pipe connection	Avloppsstos		
8	1	1	1	1	1	1	1	471 7871-07	Hose clamp	Slangklämma		
9	1	1						736 2837-51	Hose clamp	Slangklämma	Ø48-54	
			1					736 2840-51	Hose clamp	Slangklämma	Ø50-63	
				4	4	4		736 2846-51	Hose clamp	Slangklämma	Ø73-83	
10	1							432 2520-01	Hose	Slang		
		1						432 2520-02	Hose	Slang		
			1					432 2528-03	Hose	Slang		
				1	1	1		432 2528-05	Hose	Slang		
11	1	1						736 2831-51	Hose clamp	Slangklämma	Ø36-42	
			1	1	1	1		736 2837-51	Hose clamp	Slangklämma	Ø48-54	
12	1	1	1	1	1	1	1	736 2837-51	Hose clamp	Slangklämma	Ø48-54	
13	1		1					432 2508-01	Hose	Slang		
		1		1	1			432 2508-03	Hose	Slang		
						1		432 2508-04	Hose	Slang		
14	1	1	1	1	1	1	1	432 2507-01	Air tube	Luftklocka		
15	1	1	1	1	1	1	1	432 2506-01	Connection	Anslutning		
16	1	1						438 8120-01	Hose	Slang	L=940	
			1	1				438 8120-02	Hose	Slang	L=1325	
				1	1			438 8120-03	Hose	Slang	L=1600	
17	1	1	1	1	1	1	1	471 2265-69	T-pipe	T-rör		
18	1	1	1	1	1	1	1	471 2442-42	Hose	Slang	L=120	
19	1	1	1	1	1	1	1	471 2464-18	Hose	Slang	L=280	
20	3	3	3	3	3	3	3	471 7887-01	Clip	Clips		
21	1	1	1					413 3184-02	Cable set	Ledningsatts		
				1	1	1		413 3184-05	Cable set	Ledningsatts		
22	1							471 8128-59	Hose	Slang		
		1						471 8128-66	Hose	Slang		
			1					471 8128-60	Hose	Slang		
				1				471 8128-73	Hose	Slang		
					1			471 8128-62	Hose	Slang		
						1		471 8128-68	Hose	Slang		
23	2	2	2	2	2	2	2	736 2840-51	Hose clamp	Slangklämma	Ø50-63	
24	1	1	1	1	1	1	1	736 2825-51	Hose clamp	Slangklämma	Ø32	
25	1	1						438 5040-01	Drain hose	Avloppsslang	Ø50	
			1	1	1	1		471 4835-01	Drain hose	Avloppsslang	Ø75	
26	Rq	Rq	Rq	Rq							Not used	
					1	1		438 0083-01	Joint sleeve	Skarvhylsa		
27	Rq	Rq	Rq	Rq							Not used	
					1	1		471 8128-54	Hose	Slang		

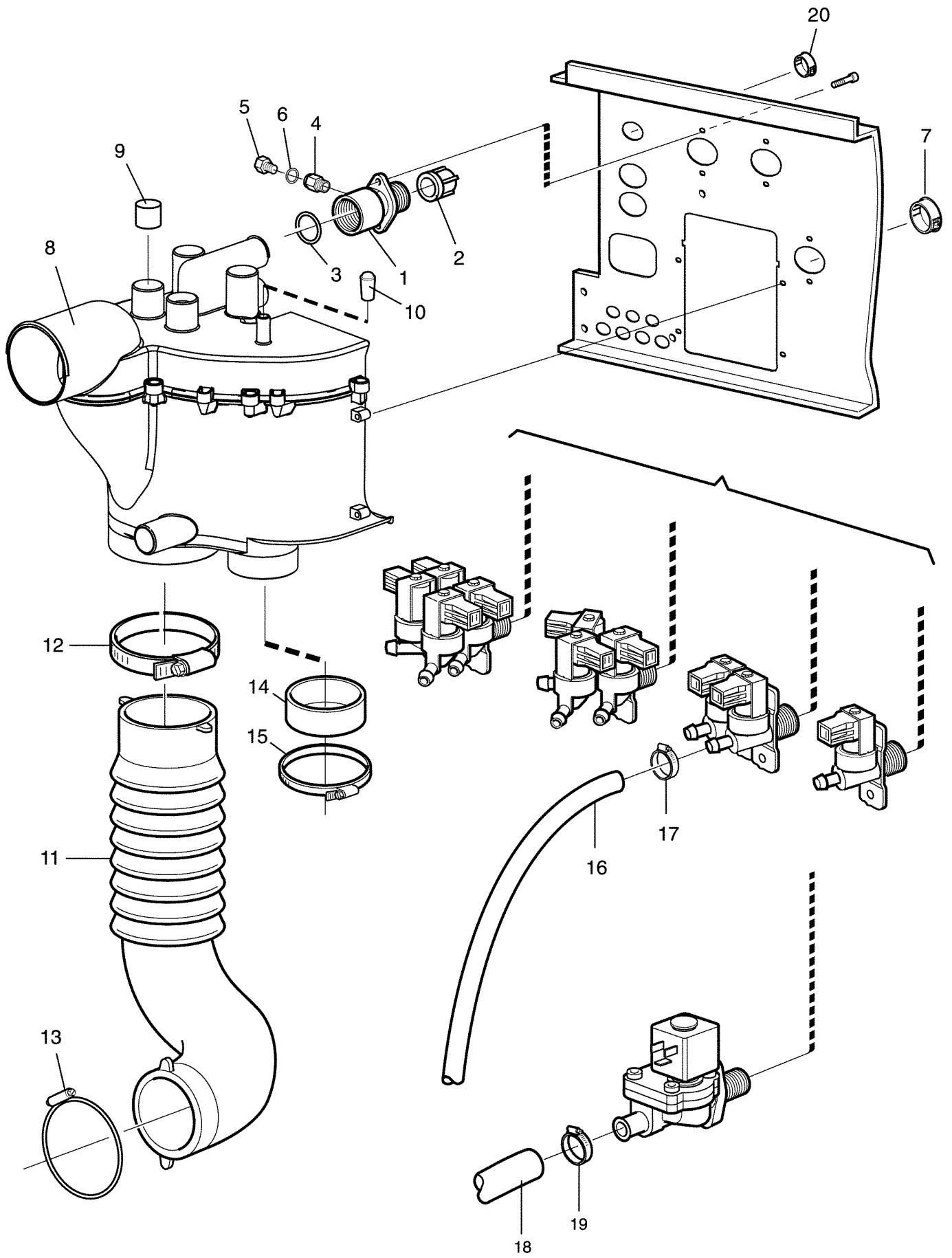



**W575H Compass,W5105H Compass,W5130H Compass,W5180H Compass,W5240H Compass,W5300H Compass**

**Water connections**

Illustration Issue Month Year  
Illustration Utgåva Månad År

**Vattenanslutningar**

**500288 1 4 2013**

Item Pos.	Quantity Antal				Art.No Art.nr	Description	Benämning	Info Info	Notes Anmärkning
	W575H Compass								
	W5105H Compass								
	W5130H Compass								
	W5180H Compass,W5240H Compass,W5300H Compass								
1	1	1	1	1	438 0056-03	Nipple	Nippel		Black, 3/4"
	1	1	1	1	438 0056-04	Nipple	Nippel		White, 3/4", USA
2	1	1	1	1	471 8693-21	Filter	Filter		
3	1	1	1	1	471 8199-01	Gasket	Packning		
4	1	1	1	1	471 8688-13	Nipple	Nippel		1/8"
5	1	1	1	1	741 5109-25	Plug	Propp		El-drain
6	1	1	1	1	740 4206-00	O-ring	O-ring		El-drain
7	Rq	Rq	Rq	Rq	471 7977-04	Cover plug	Täckpropp		
8	1	1	1	1	432 2320-01	Siphon breaker	Återsugningsskydd		
9	Rq	Rq	Rq	Rq	471 8175-01	Plug	Plugg		
10	1	1	1	1	471 8644-02	Plug	Propp		
11	1				432 2312-01	Hose	Slang		
		1			432 2305-01	Hose	Slang		
			1	1	432 2306-01	Hose	Slang		
12	1	1	1	1	736 2846-51	Hose clamp	Slangklämma		Ø73-83
13	1	1			471 7871-08	Hose clamp	Slangklämma		
			1	1	471 7871-04	Hose clamp	Slangklämma		
14	1	1			471 2409-89	Hood	Huv		Pump
			Rq	Rq					Not used
15	1	1			736 2837-51	Hose clamp	Slangklämma		Ø48-54 Pump
			Rq	Rq					Not used
16	Rq	Rq	Rq	Rq	877 5211-08	Hose	Slang		Per 1 m
17	Rq	Rq	Rq	Rq	736 2816-51	Hose clamp	Slangklämma		Ø13-19
18	Rq	Rq	Rq						Not used
				Rq	432 2308-01	Hose	Slang		Hard water
				Rq	432 2314-01	Hose	Slang		
19	Rq	Rq	Rq						Not used
				1	736 2825-51	Hose clamp	Slangklämma		Ø32
20	1	1	1	1	471 7977-01	Cover plug	Täckpropp		

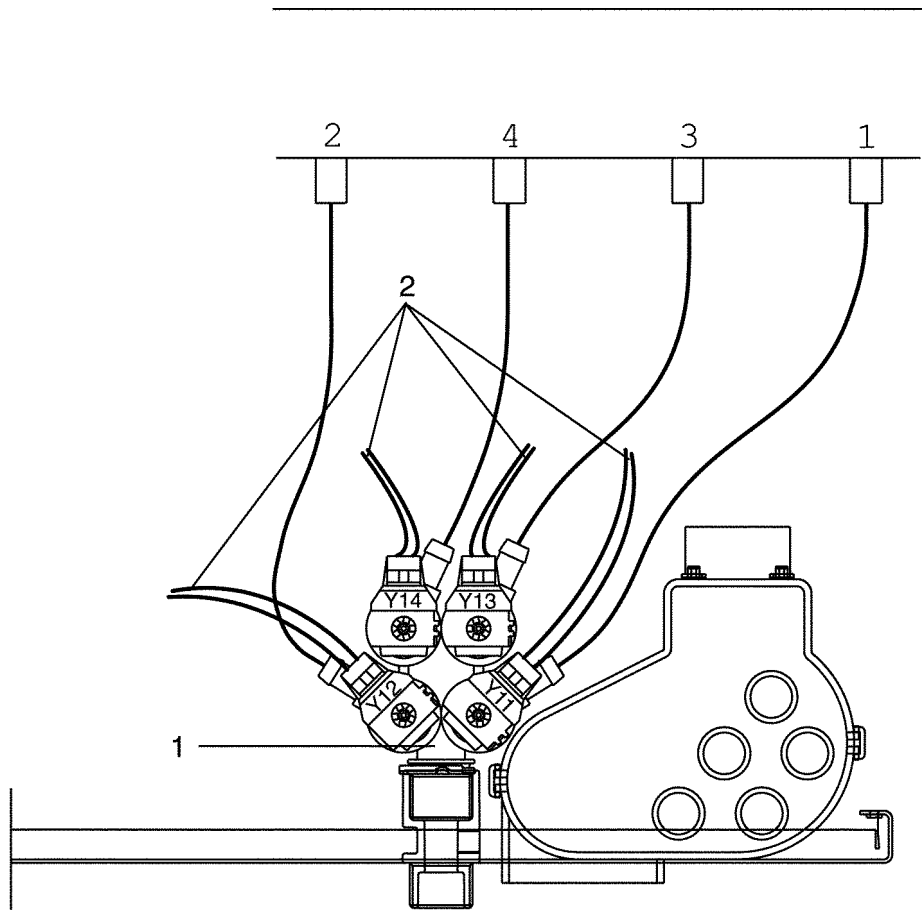



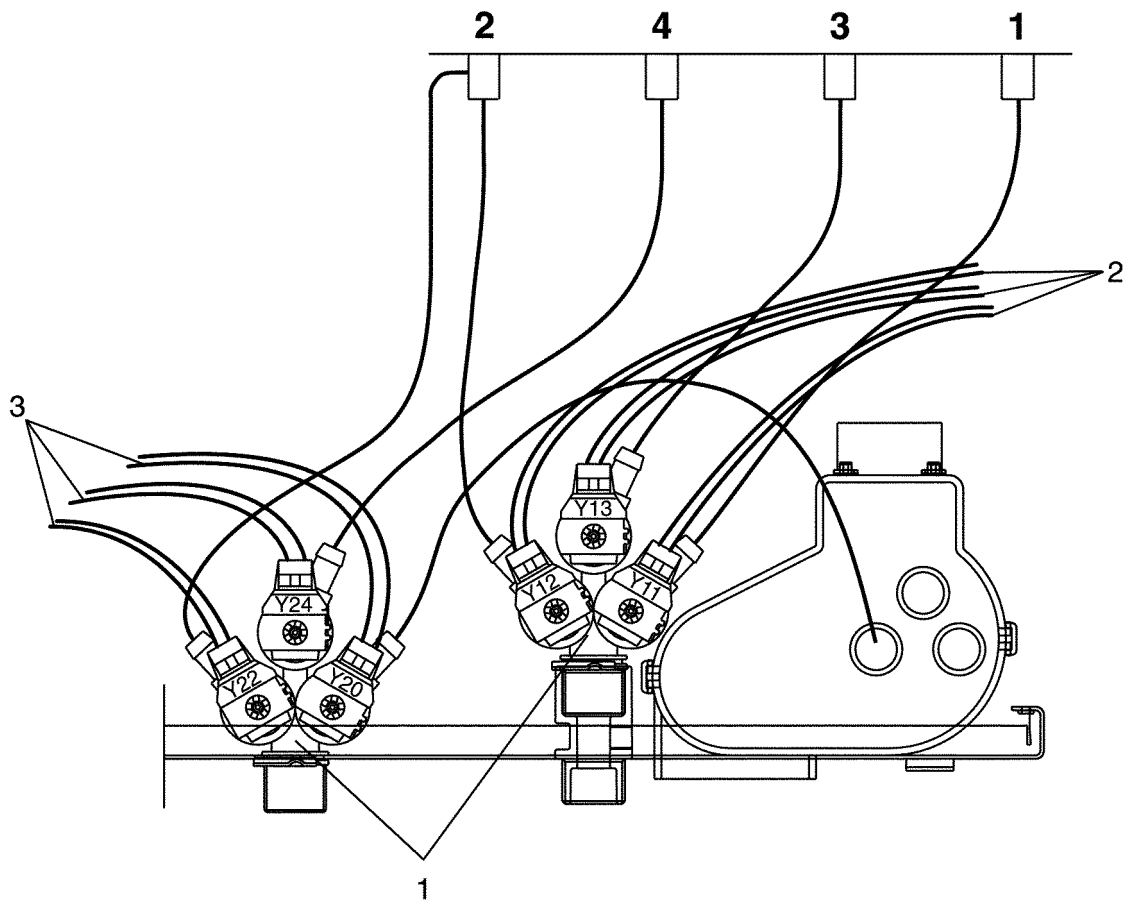

**W575H Compass,W5105H Compass,W5130H Compass**

**Inlet valves and cable set**

Illustration Issue Month Year  
Illustration Utgåva Månad År  
**500290 1 4 2013**

**Inloppsventiler och ledningssatser**

Item Pos.	Quantity Antal	Art.No Art.nr	Description	Benämning	Info Info	Notes Anmärkning
<b>1</b>	W575H Compass					
	W5105H Compass					
	W5130H Compass					
	2	2	<b>471 8236-76</b>	Valve	Ventil	3-way, 208-240V
	2	2	<b>471 8236-78</b>	Valve	Ventil	50/60Hz, BSP
	2		<b>471 8236-79</b>	Valve	Ventil	3-way, 208-240V
						50/60Hz, NH USA US
						3-way, 120V 60Hz, NH USA US
<b>2</b>	1		<b>413 3086-07</b>	Cable set	Ledningssats	Cold
		1	<b>413 3086-07</b>	Cable set	Ledningssats	Cold
<b>3</b>	1		<b>413 3086-08</b>	Cable set	Ledningssats	Hot
		1	<b>413 3086-08</b>	Cable set	Ledningssats	Hot

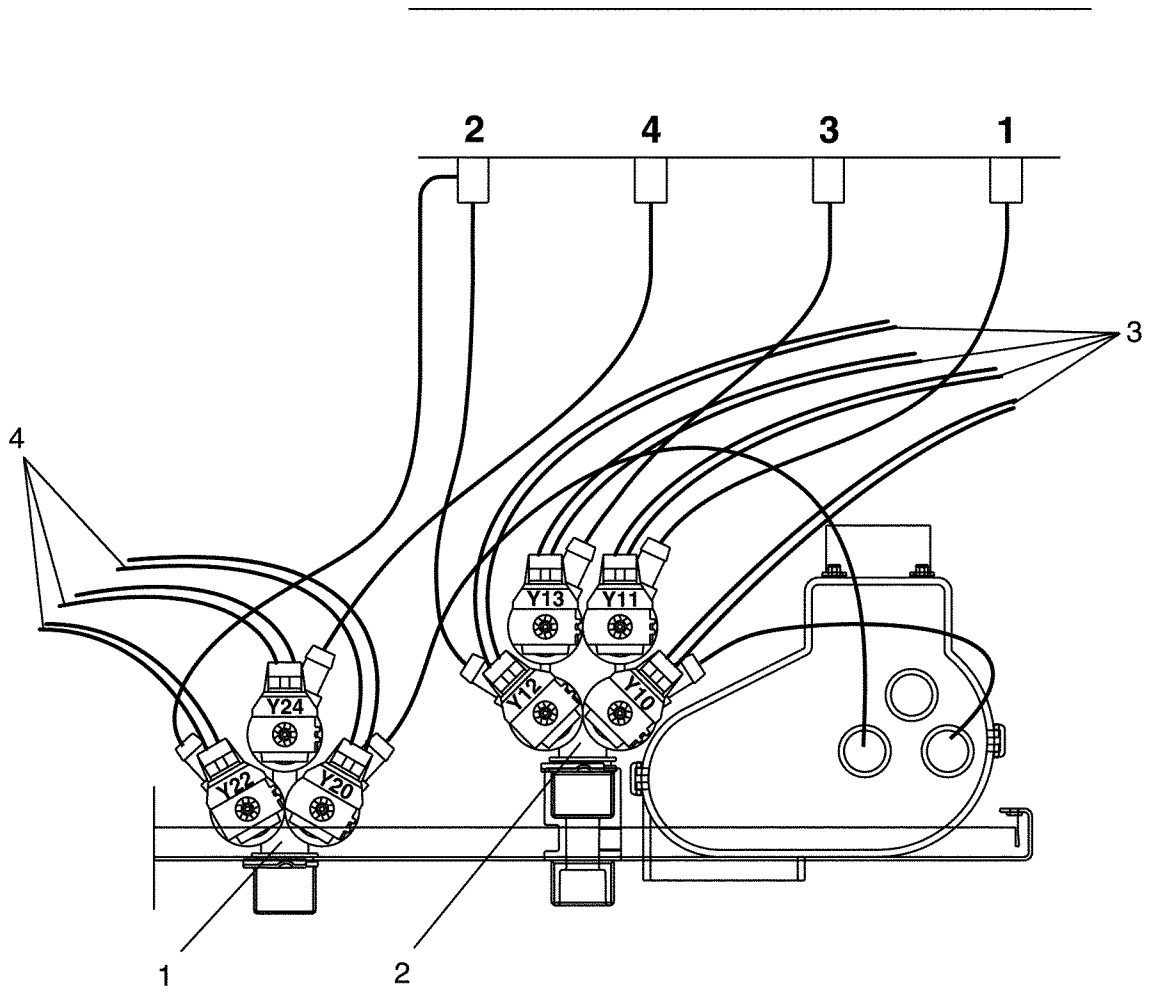

**W575H Compass,W5105H Compass,W5130H Compass,W5180H Compass**

**Inlet valves and cable set**

Illustration Issue Month Year  
Illustration Utgåva Månad År  
**500291 1 4 2013**

**Inloppsventiler och ledningssatser**

Item Pos.	Quantity Antal	Art.No Art.nr	Description	Benämning	Info Info	Notes Anmärkning
			W575H Compass			
			W5105H Compass			
			W5130H Compass			
			W5180H Compass			
1	1	471 8236-76	Valve	Ventil		3-way, 208-240V 50/60Hz, BSP
	1	471 8236-78	Valve	Ventil		3-way, 208-240V 50/60Hz, NH USA US
	1	471 8236-79	Valve	Ventil		3-way, 120V 60Hz, NH USA US
2	1	471 8240-64	Valve	Ventil		4-way, 208-240V 50/60Hz, BSP
	1	471 8240-67	Valve	Ventil		4-way, 120V 60Hz, NH USA
	1	471 8240-68	Valve	Ventil		4-way, 208-240V 50/60Hz, NH USA US
3	1	413 3088-07	Cable set	Ledningssats		Cold
	1	413 3088-07	Cable set	Ledningssats		
	1	413 3088-10	Cable set	Ledningssats		
4	1	413 3086-08	Cable set	Ledningssats		Hot
	1	413 3086-08	Cable set	Ledningssats		
	1	413 3086-10	Cable set	Ledningssats		

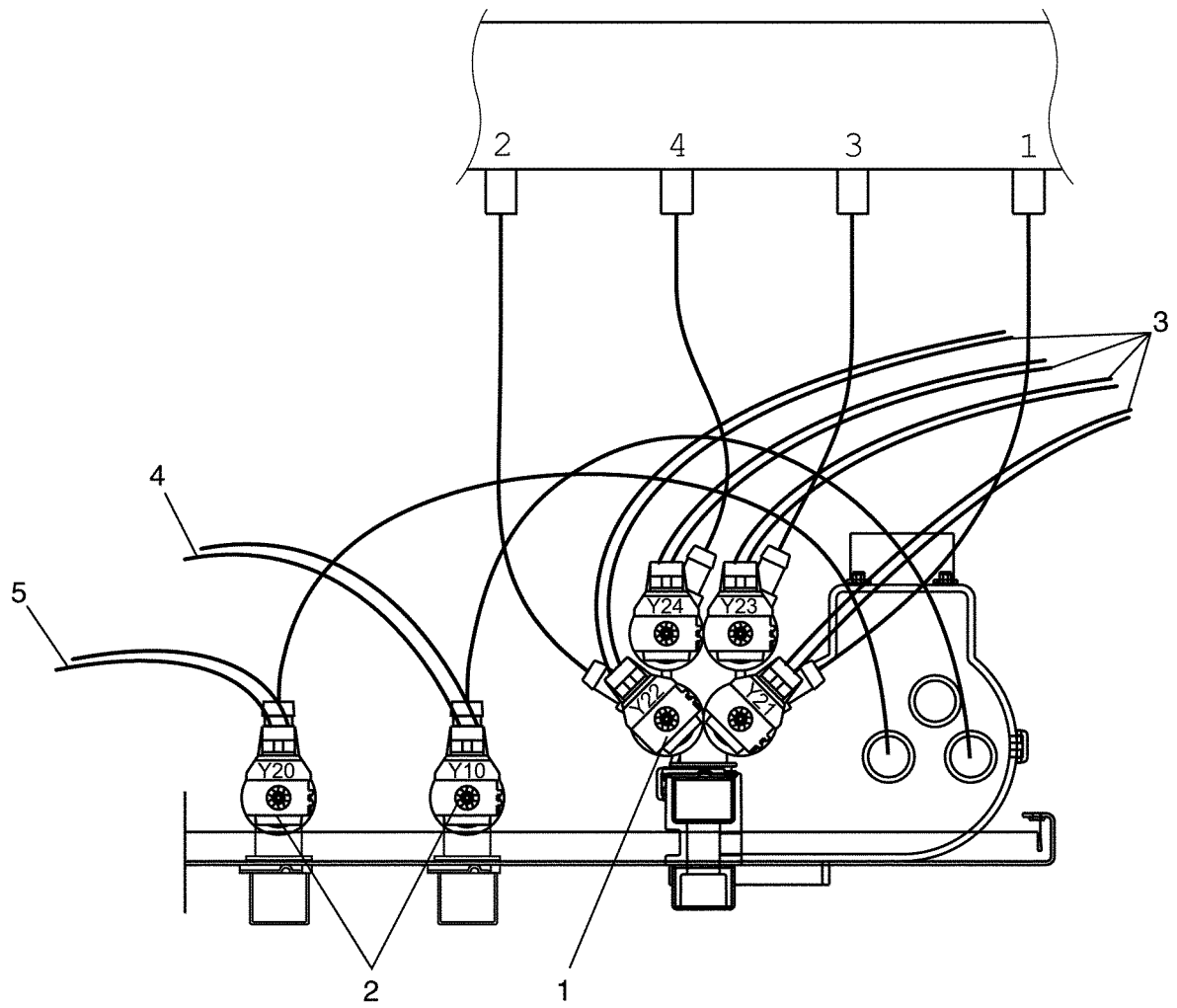



**W575H Compass,W5105H Compass,W5130H Compass**

**Inlet valves and cable set**

Illustration Issue Month Year  
Illustration Utgåva Månad År  
**500292 1 4 2013**

**Inloppsventiler och ledningssatser**

Item Pos.	Quantity Antal	Art.No Art.nr	Description	Benämning	Info Info	Notes Anmärkning
			W575H Compass			
			W5105H Compass			
			W5130H Compass			
<b>1</b>	1	1	<b>471 8240-63</b> Valve	Ventil		4-way, 208-240V 50/60Hz, BSP
	1	1	<b>471 8240-69</b> Valve	Ventil		4-way, 208-240V 50/60Hz, NH USA USA
<b>2</b>	2	2	<b>471 8234-52</b> Valve	Ventil		1-way, 208-240V 50/60Hz, BSP
<b>3</b>	1		<b>413 3088-07</b> Cable set	Ledningssats		Cold
		1	<b>413 3088-07</b> Cable set	Ledningssats		Cold
<b>4</b>	1		<b>413 3082-21</b> Cable set	Ledningssats		Cold
		1	<b>413 3082-29</b> Cable set	Ledningssats		Cold
<b>5</b>	1		<b>413 3082-30</b> Cable set	Ledningssats		Hot
		1	<b>413 3082-30</b> Cable set	Ledningssats		Hot

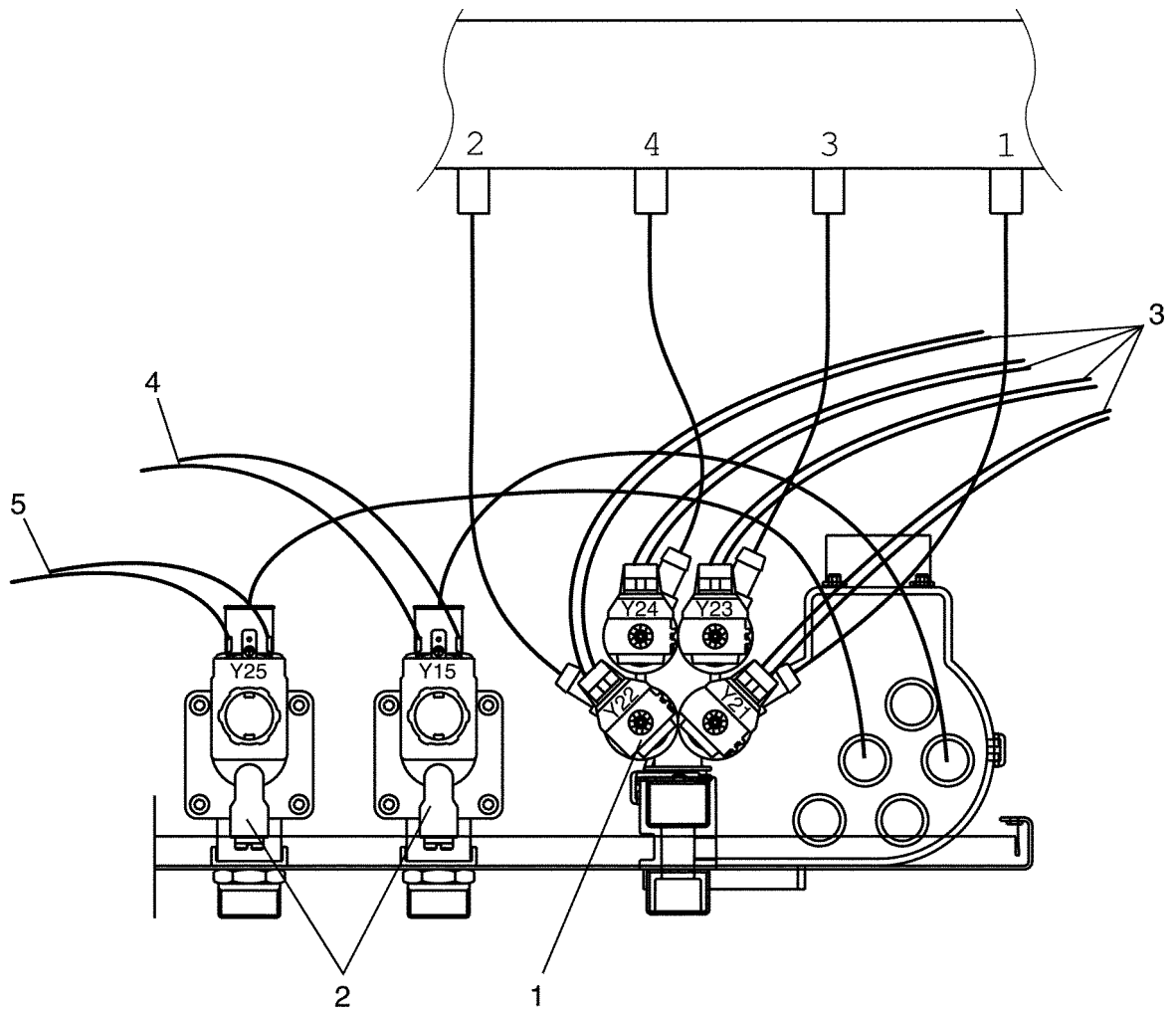

**W5130H Compass,W5180H Compass,W5240H Compass**

**Inlet valves and cable set**

Illustration Issue Month Year  
Illustration Utgåva Månad År  
**500302 1 4 2013**

**Inloppsventiler och ledningssatser**

Item Pos.	Quantity Antal	Art.No Art.nr	Description	Benämning	Info Info	Notes Anmärkning
			W5130H Compass			
			W5180H Compass			
			W5240H Compass			
1	1	1	1 471 8240-63 Valve	Ventil		4-way, 208-240V 50/60Hz, BSP
	1	1	1 471 8240-69 Valve	Ventil		4-way, 208-240V 50/60Hz, NH USA USA
2	2	2	2 471 8210-70 Valve	Ventil		208-240V 50/60Hz, BSP
	1	1	1 471 8210-79 •Coil	•Spole		50/60 Hz
	2	2	2 471 8210-71 Valve	Ventil		208-240V 60Hz, NH USA USA
	1	1	1 471 8210-78 •Coil	•Spole		60Hz
3	1		1 413 3088-08 Cable set	Ledningssats		
		1	1 413 3088-10 Cable set	Ledningssats		
		1	1 413 3088-10 Cable set	Ledningssats		
4	1		1 413 3182-09 Cable set	Ledningssats		
		1	1 413 3182-15 Cable set	Ledningssats		
		1	1 413 3182-15 Cable set	Ledningssats		
5	1		1 413 3182-10 Cable set	Ledningssats		
		1	1 413 3182-16 Cable set	Ledningssats		
		1	1 413 3182-16 Cable set	Ledningssats		

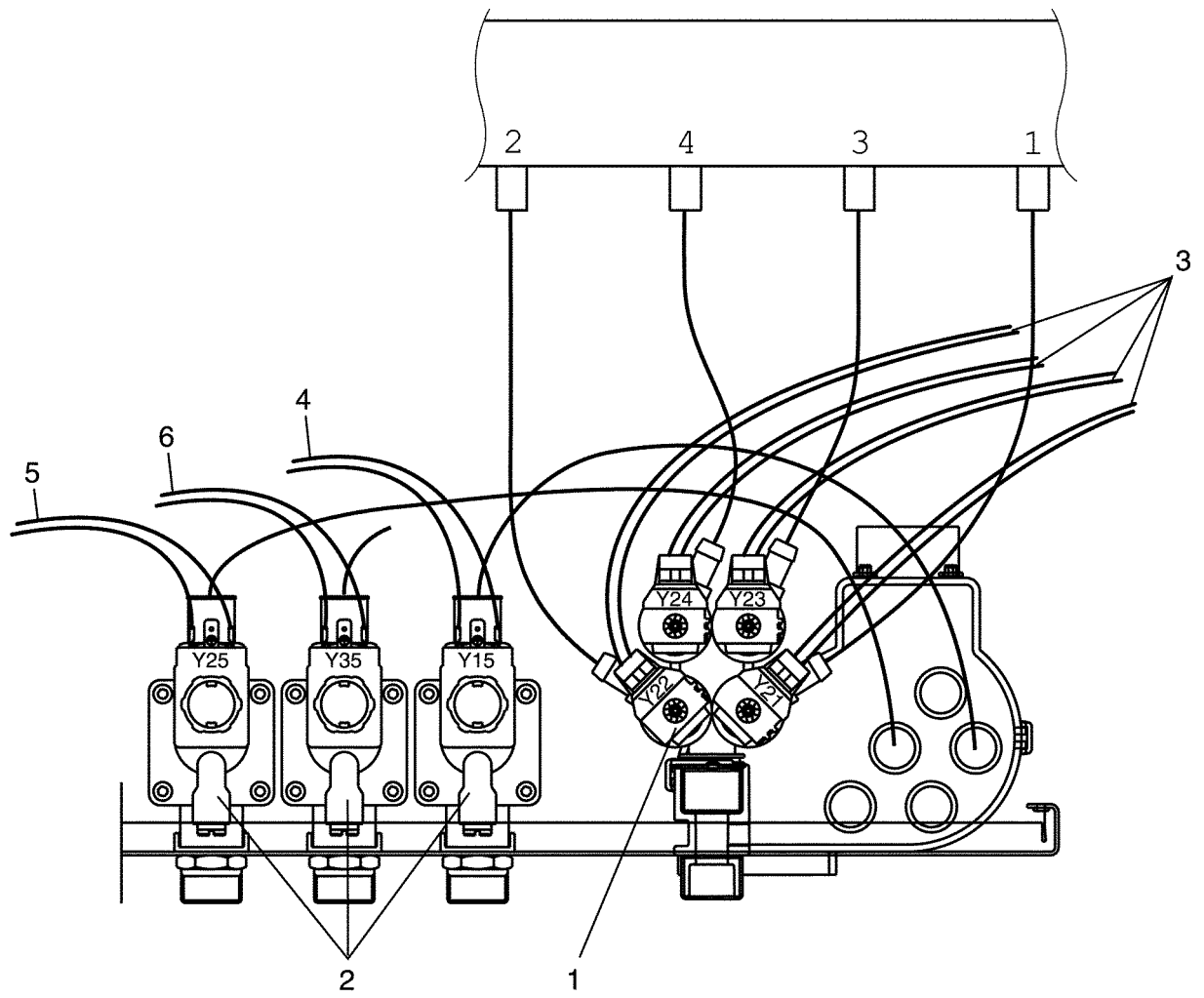

**W5130H Compass,W5180H Compass,W5240H Compass,W5300H Compass**

**Inlet valves and cable set**

Illustration Issue Month Year  
Illustration Utgåva Månad År  
**500303 1 4 2013**

**Inloppsventiler och ledningssatser**

Item Pos.	Quantity Antal	Art.No Art.nr	Description	Benämning	Info Info	Notes Anmärkning		
			W5130H Compass					
			W5180H Compass					
			W5240H Compass					
			W5300H Compass					
1	1	1	1	1	471 8240-63	Valve	Ventil	4-way, 208-240V 50/60Hz, BSP
	1	1	1	1	471 8240-69	Valve	Ventil	4-way, 208-240V 50/60Hz, NH USA USA
2	3	3	3	3	471 8210-70	Valve	Ventil	208-240V 50/60Hz, BSP
	1	1	1	1	471 8210-79	•Coil	•Spole	50/60 Hz
	3	3	3	3	471 8210-71	Valve	Ventil	208-240V 60Hz, NH USA USA
	1	1	1	1	471 8210-78	•Coil	•Spole	60Hz
3	1				413 3088-08	Cable set	Ledningssats	
		1			413 3088-10	Cable set	Ledningssats	
			1	1	413 3088-10	Cable set	Ledningssats	
4	1				413 3182-09	Cable set	Ledningssats	
		1			413 3182-15	Cable set	Ledningssats	
			1	1	413 3182-15	Cable set	Ledningssats	
5	1				413 3182-10	Cable set	Ledningssats	
		1			413 3182-16	Cable set	Ledningssats	
			1	1	413 3182-16	Cable set	Ledningssats	
6	1				413 3182-11	Cable set	Ledningssats	
		1			413 3182-14	Cable set	Ledningssats	
			1	1	413 3182-17	Cable set	Ledningssats	

1

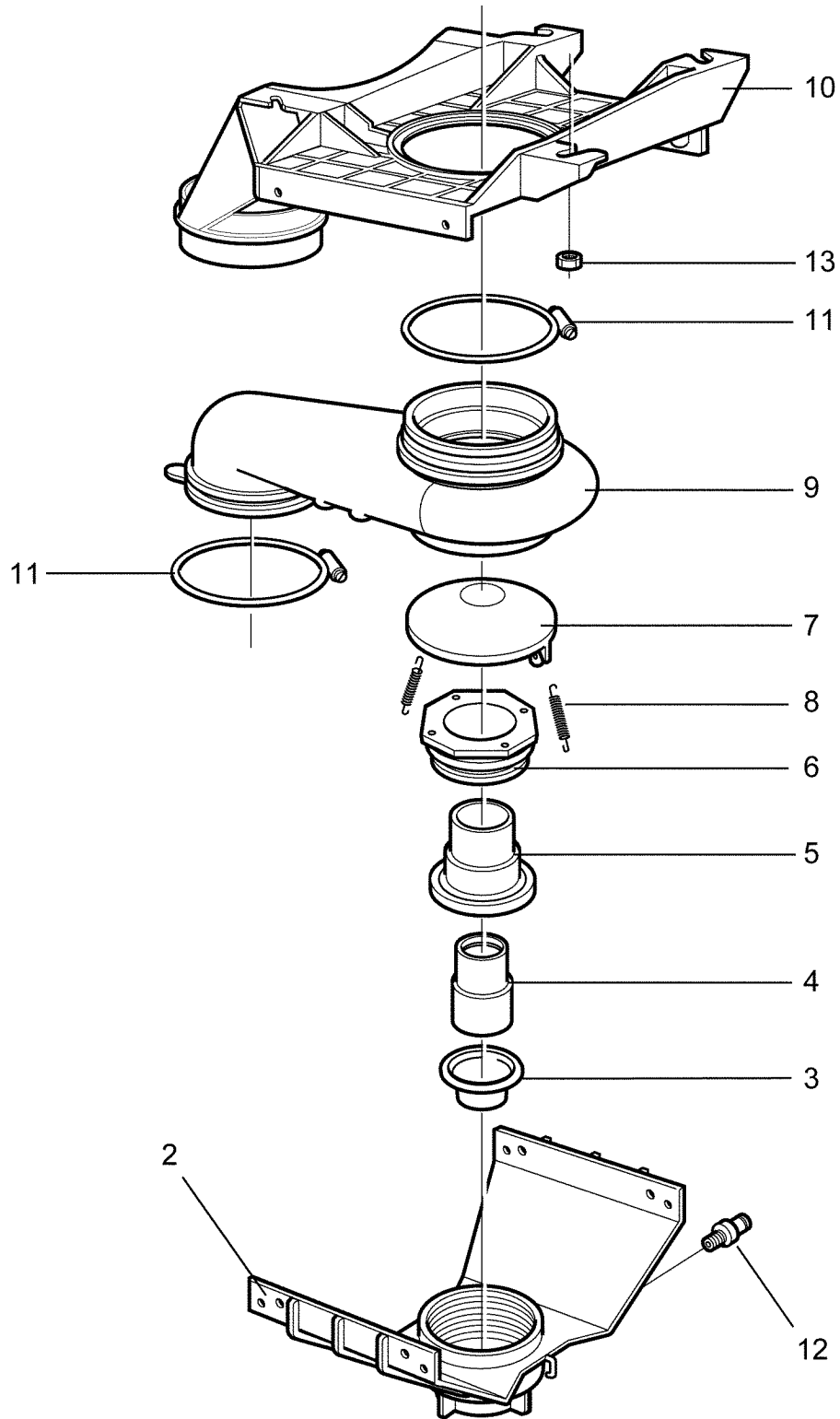

**W575H Compass,W5105H Compass,W5130H Compass,W5180H Compass,W5240H Compass,W5300H Compass**

**Drain valve**

Illustration Issue Month Year  
Illustration Utgåva Månad År

**Avloppsventil**

**500293 1 4 2013**

Item Pos.	Qua. Ant.	Art.No Art.nr	Description	Benämning	Info Info	Notes Anmärkning
1	1	432 2502-01	Drain valve	Avloppsventil		
2	1	438 0051-01	•Lower frame	•Underdel		
3	1	471 8195-01	•Diaphragm	•Membran		
4	1	438 0054-01	•Piston	•Kolv		
5	1	438 0053-01	•Housing	•Hus		
6	1	438 0055-01	•Gland	•Gland		
7	1	438 0052-01	•Cover	•Lock		
8	2	471 7818-01	•Spring	•Fjäder		
9	1	432 2505-01	•Hose housing	•Slanghus		
10	1	432 2501-01	•Upper frame	•Överdel		
11	2	471 7871-04	•Hose clamp	•Slangklämma		
12	1	471 8688-13	•Nipple	•Nippel		1/8"
13	4	471 8404-03	Nut	Mutter		M6 Stainless

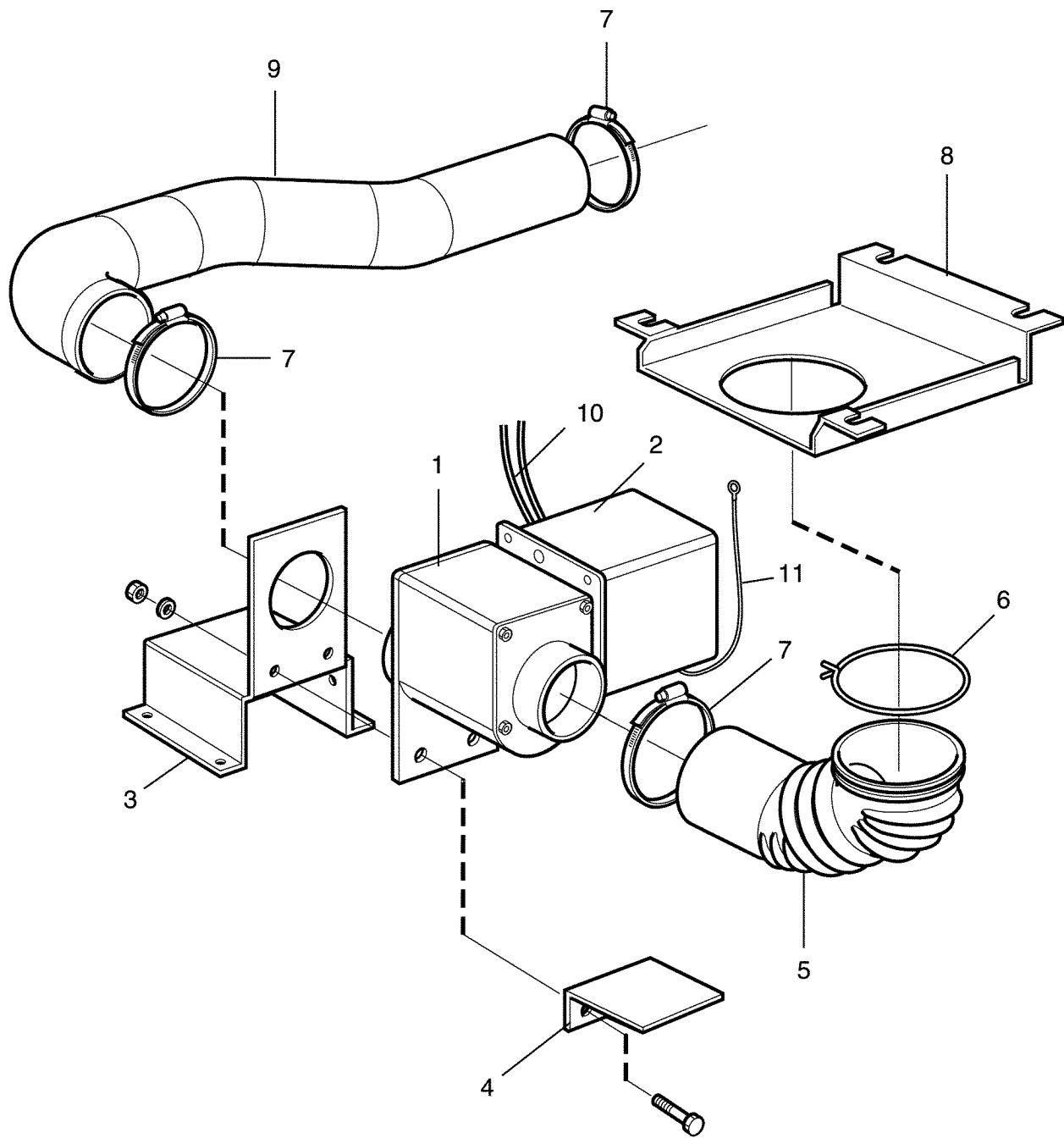



**W575H Compass,W5105H Compass,W5130H Compass,W5180H Compass,W5240H Compass,W5300H Compass**

**Drain valve, electrical**

Illustration Issue Month Year  
Illustration Utgåva Månad År

**Avloppsventil, elektrisk**

**500294 1 4 2013**

Item Pos.	Quantity Antal		Art.No Art.nr	Description	Benämning	Info Info	Notes Anmärkning	
	W575H Compass							
	W5105H Compass							
	W5130H Compass							
	W5180H Compass							
	W5240H Compass							
	W5300H Compass							
1	1	1	471 9219-65	Drain valve	Avloppsventil		50/60Hz	
		1	471 8215-01	Drain valve	Avloppsventil		50/60Hz	
		1	471 8215-03	Drain valve	Avloppsventil		50/60Hz Normally closed	
2	1	1	432 2548-01	Cover	Kåpa			
3	1	1	432 2530-02	Mounting plate	Fästplåt			
		1	432 2531-01	Mounting plate	Fästplåt			
4	1	1	432 2536-01	Support	Stöd			
		1	432 2537-01	Support	Stöd			
5	1		432 2524-01	Hose	Slang			
		1	432 2524-02	Hose	Slang			
		1	432 2516-04	Hose	Slang			
		1	432 2516-05	Hose	Slang			
6	1	1	471 7871-07	Hose clamp	Slangklämma			
7	3	3	736 2837-51	Hose clamp	Slangklämma		Ø48-54	
		3	736 2846-51	Hose clamp	Slangklämma		Ø73-83	
8	1	1	432 2534-01	Mounting plate	Fästplåt			
9	1	1	432 2517-01	Hose	Slang			
		1	432 2518-01	Hose	Slang			
		1	432 2518-03	Hose	Slang			
		1	432 2518-04	Hose	Slang			
10	1		413 2902-02	Cable set	Ledningssats			
		1	413 2902-04	Cable set	Ledningssats			
		1	413 2902-06	Cable set	Ledningssats			
		1	413 2902-08	Cable set	Ledningssats			
		1	413 2902-10	Cable set	Ledningssats			
		1	413 2902-12	Cable set	Ledningssats			
11	1	1	432 2982-10	Ground cable	Jordkabel		NO NC	

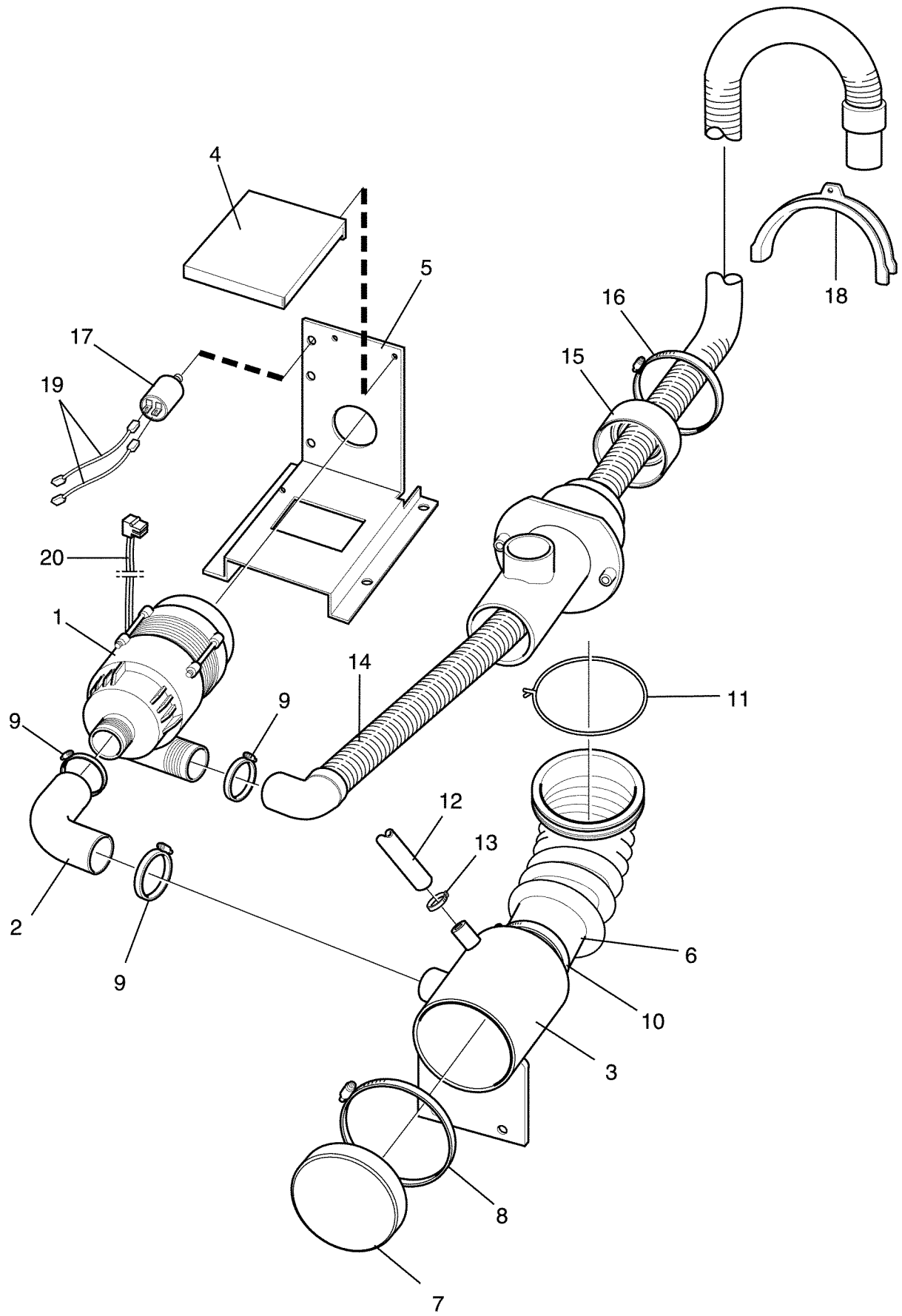

**W575H Compass,W5105H Compass**

**Drain pump**

**Avloppspump**

Illustration Issue Month Year  
Illustration Utgåva Månad År  
**500295 2 10 2013**

Item Pos.	Quantity Antal	Art.No Art.nr	Description	Benämning	Info Info	Notes Anmärkning
			W575H Compass			
			W5105H Compass			
1	1	1	438 8270-01	Drain pump	Avloppspump	230V 50Hz Complete 230V 60Hz Complete
	1	1	438 8270-02	Drain pump	Avloppspump	
2	1	1	471 4391-02	Hose	Slang	
3	1	1	432 2533-01	Container	Behållare	
4	1	1	432 2538-01	Cover	Skydd	
5	1	1	432 2532-01	Mounting plate	Fästplåt	
6	1		432 2524-01	Hose	Slang	
		1	432 2524-02	Hose	Slang	
7	1	1	472 6760-01	Hood	Huv	
8	1	1	736 2849-51	Hose clamp	Slangklämma	Ø77-93
9	3	3	736 2825-51	Hose clamp	Slangklämma	Ø32
10	1	1	736 2837-51	Hose clamp	Slangklämma	Ø48-54
11	1	1	471 7871-07	Hose clamp	Slangklämma	
* 12	1	1	471 8116-17	Hose	Slang	L=1560
13	1	1	736 2816-51	Hose clamp	Slangklämma	Ø13-19
14	1	1	471 6858-82	Drain hose	Avloppsslang	
15	1	1	438 5022-01	Discharge	Avlastning	
16	1	1	736 2840-51	Hose clamp	Slangklämma	Ø50-63
17	1	1	438 9515-01	Capacitor	Kondensator	4µF
18	1	1	471 6858-83	Bracket	Hållare	
19	2	2	432 2954-26	Cable set	Ledningssats	
20	1		413 2903-02	Cable set	Ledningssats	
		1	413 2903-04	Cable set	Ledningssats	

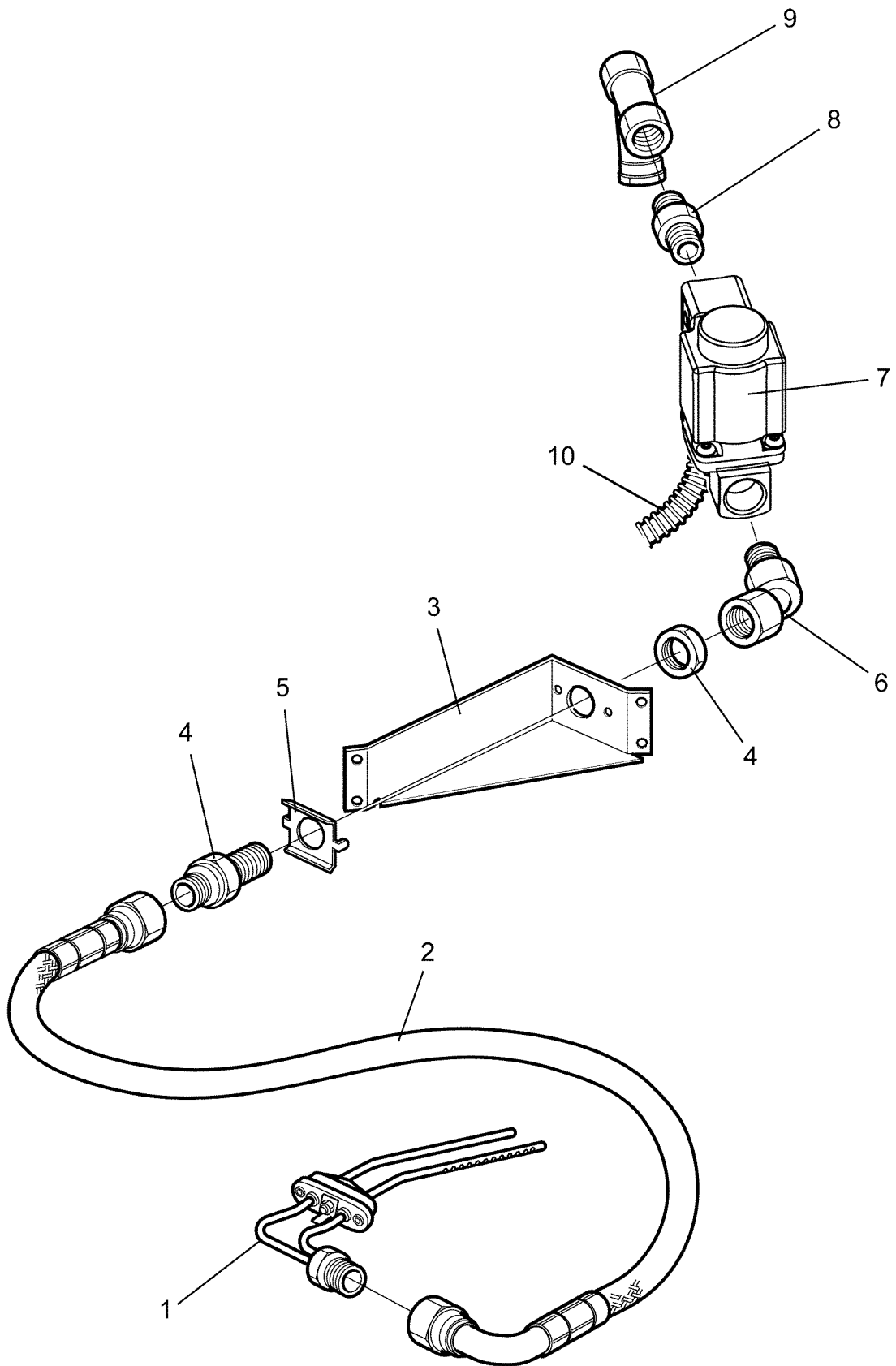

**W575H Compass,W5105H Compass,W5130H Compass,W5180H Compass,W5240H Compass,W5300H Compass**

**Steam components**

Illustration Issue Month Year  
Illustration Utgåva Månad År  
**500296 2 3 2014**

**Ångdetaljer**

Item Pos.	Quantity Antal		Art.No Art.nr	Description	Benämning	Info Info	Notes Anmärkning
	W575H Compass						
	W5105H Compass						
	W5130H Compass						
	W5180H Compass						
	W5240H Compass						
	W5300H Compass						
1	1	1		432 1630-01 Steam injector	Ånginjektor		
		1	1	432 1631-01 Steam injector	Ånginjektor		
2	1			471 8126-25 Steam hose	Ångslang		
		1		471 8126-26 Steam hose	Ångslang		
			1	471 8126-27 Steam hose	Ångslang		
			1	471 8126-28 Steam hose	Ångslang		
				471 8126-29 Steam hose	Ångslang		
			1	471 8126-38 Steam hose	Ångslang		
3	1	1	1	432 1673-01 Bracket	Konsol		
4	1	1	1	471 8695-01 Nipple	Nippel		
5	1	1	1	471 2937-01 Bracket	Vridskydd		
6	1	1	1	471 8697-01 Adapter	Adapter		
7	1	1	1	472 9920-31 Valve	Ventil		
	1	1	1	471 8279-08 •Repair kit	•Reparationsats		
8	1	1	1	471 8624-01 Nipple	Nippel		1/2"
9	1	1	1	744 3113-06 Filter	Filter		1/2"
10	1	1	1	432 3058-04 Cable set	Ledningssats		

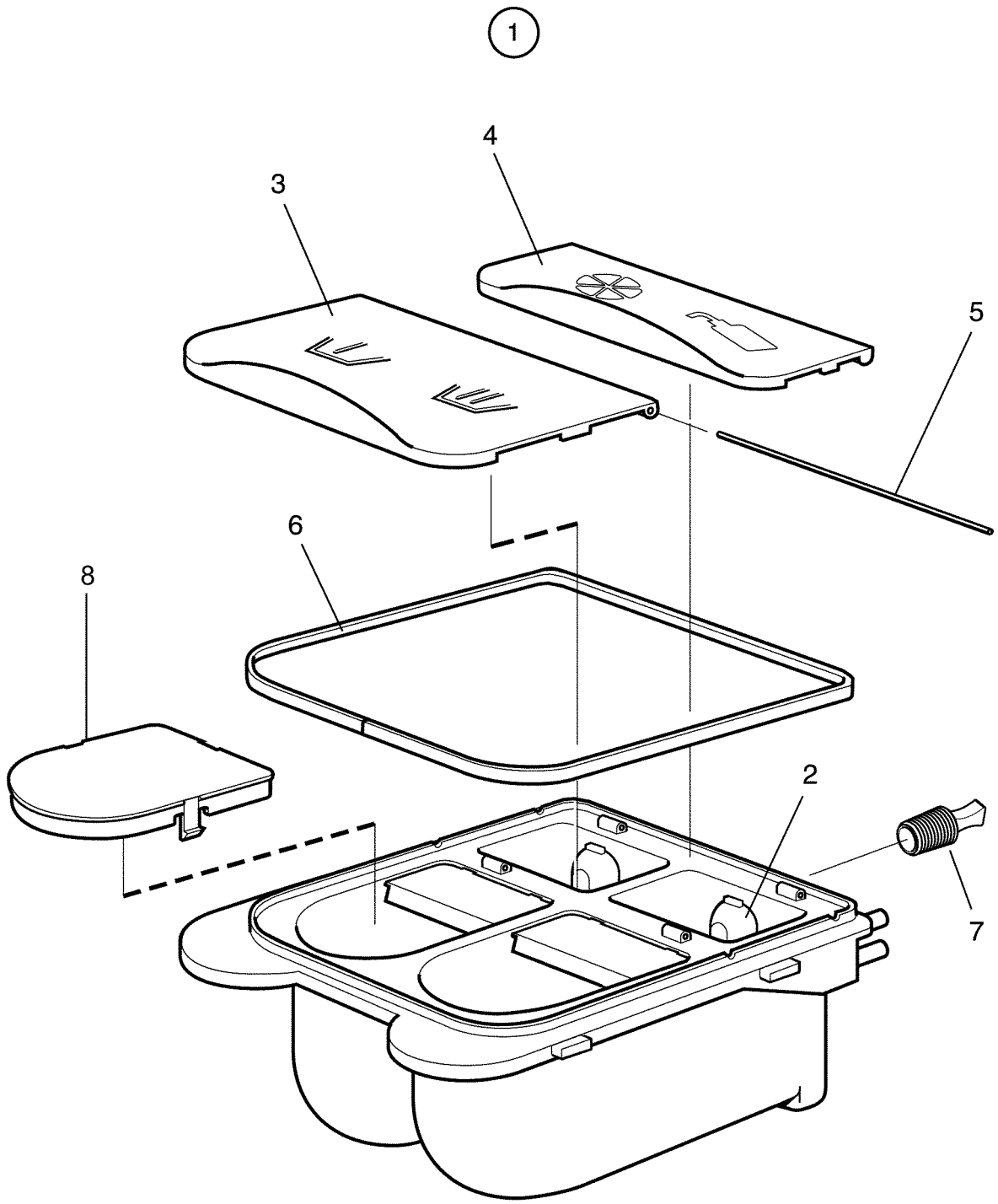

**W575H Compass,W5105H Compass,W5130H Compass,W5180H Compass,W5240H Compass,W5300H Compass**

**Detergent container**

Illustration Issue Month Year  
Illustration Utgåva Månad År

**Tvättmedelsbehållare**

**500297 1 4 2013**

Item Pos.	Qua. Ant.	Art.No Art.nr	Description	Benämning	Info Info	Notes Anmärkning
<b>1</b>	1	<b>472 9954-01</b>	Detergent container	Tvättmedelsbehållare		USA
	1	<b>472 9954-03</b>	Detergent container	Tvättmedelsbehållare		
<b>2</b>	2	<b>432 2404-51</b>	•Siphon	•Hävert		
<b>3</b>	1	<b>432 2405-02</b>	•Cover	•Lock		
<b>4</b>	1	<b>432 2406-02</b>	•Cover	•Lock		
<b>5</b>	2	<b>432 2407-01</b>	•Shaft	•Axel		
<b>6</b>	1	<b>432 2412-01</b>	•Gasket	•Packning		
<b>7</b>	1	<b>432 2413-01</b>	•Rubber plug	•Gummiplugg		
<b>8</b>	1	<b>432 2409-01</b>	Cover	Kåpa		

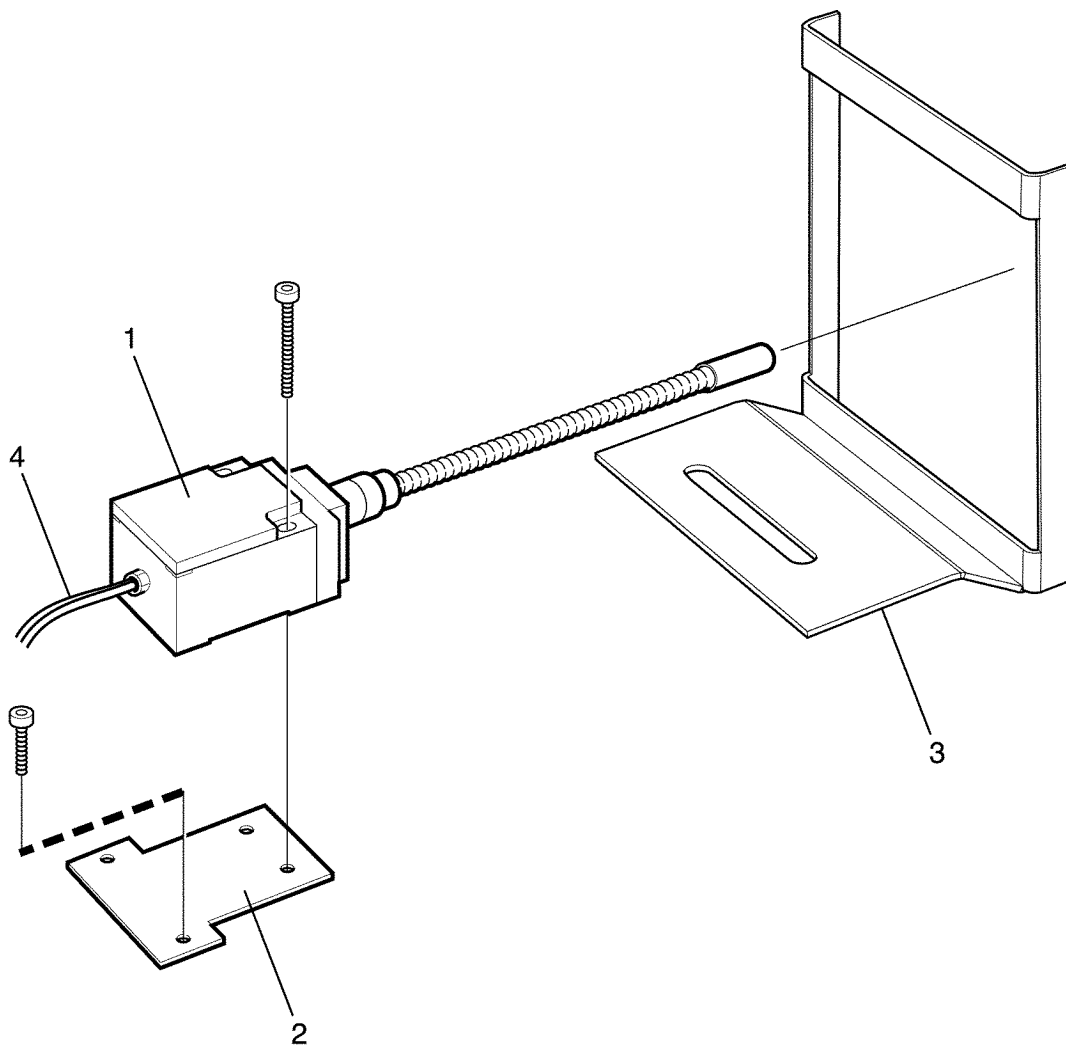



**W5130H Compass,W5180H Compass,W5240H Compass,W5300H Compass**

**Out of balance switch**

Illustration	Issue	Month	Year
Illustration	Utgåva	Månad	År
<b>500304</b>	<b>1</b>	<b>4</b>	<b>2013</b>

**Obalansbrytare**

Item Pos.	Quantity Antal	Art.No Art.nr	Description	Benämning	Info Info	Notes Anmärkning
W5130H Compass,W5180H Compass						
W5240H Compass,W5300H Compass						
<b>1</b>	1	1	<b>471 9608-01</b> Out of balance switch	Obalansbrytare		
<b>2</b>	1	1	<b>432 2183-01</b> Mounting plate	Monteringsplåt		
<b>3</b>	1	1	<b>432 2202-02</b> Frame	Ram		
		1	<b>432 2202-01</b> Frame	Ram		
<b>4</b>	1	1	<b>432 2987-01</b> Cable set	Ledningssats		

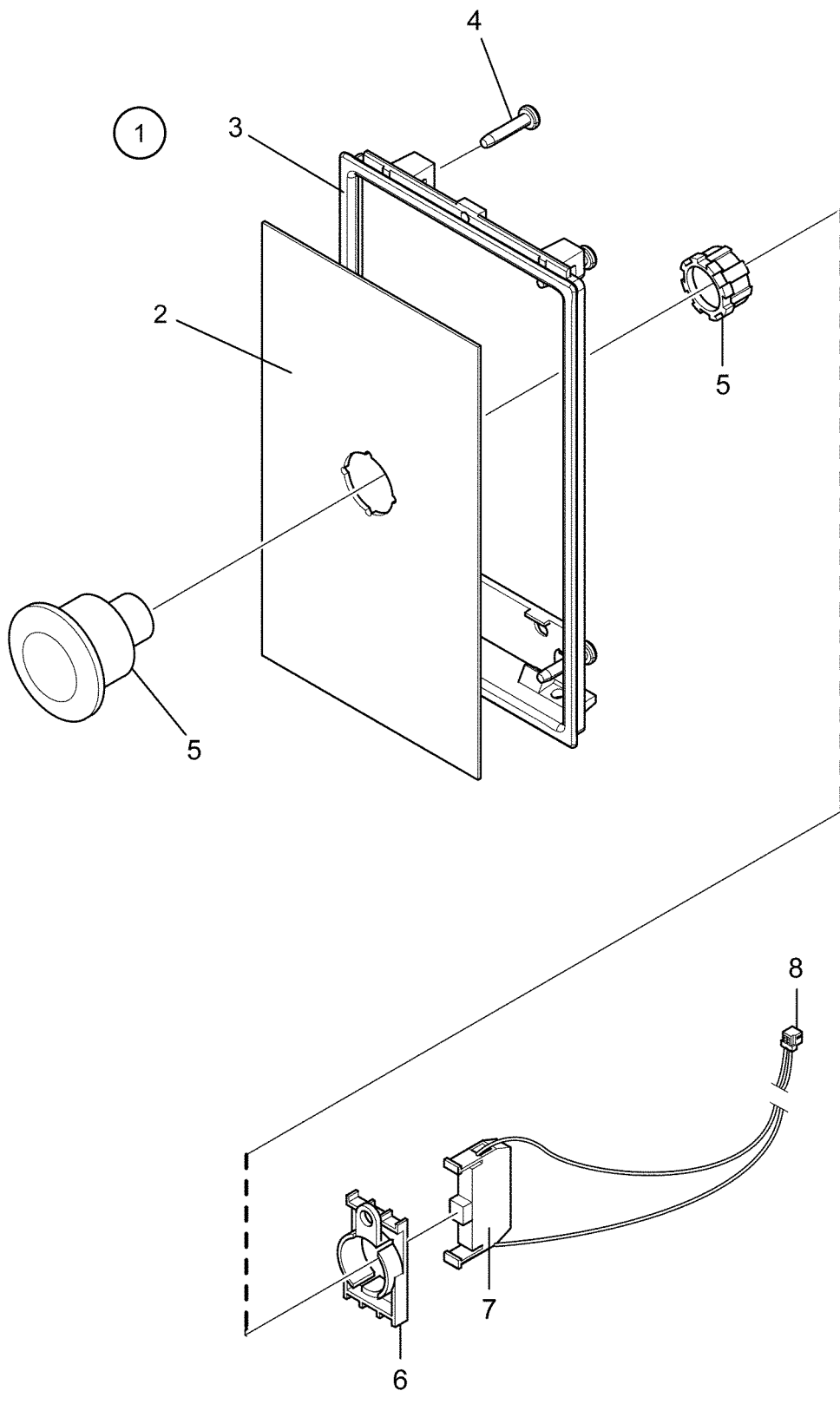

**W575H Compass,W5105H Compass,W5130H Compass,W5180H Compass,W5240H Compass,W5300H Compass**

**Emergency stop**

Illustration Issue Month Year  
Illustration Utgåva Månad År

**Nödstopp**

**500315 1 4 2013**

Item Pos.	Qua. Ant.	Art.No Art.nr	Description	Benämning	Info Info	Notes Anmärkning
<b>1</b>	1	<b>472 9955-07</b>	Cover plates	Täckplåtar		Kit compl.
<b>2</b>	1		•Cover plate	•Täckplåt		
<b>3</b>	1		•Frame	•Ram		
<b>4</b>	4		•Screw	•Skruv		
<b>5</b>	1	<b>471 9628-32</b>	Emergency stop	Nödstopp		
<b>6</b>	1	<b>471 9628-75</b>	Bracket	Hållare		
<b>7</b>	1	<b>471 9628-71</b>	Socket	Kontaktblock		NO Green
<b>8</b>	1	<b>413 3272-19</b>	Cable set	Ledningssats		

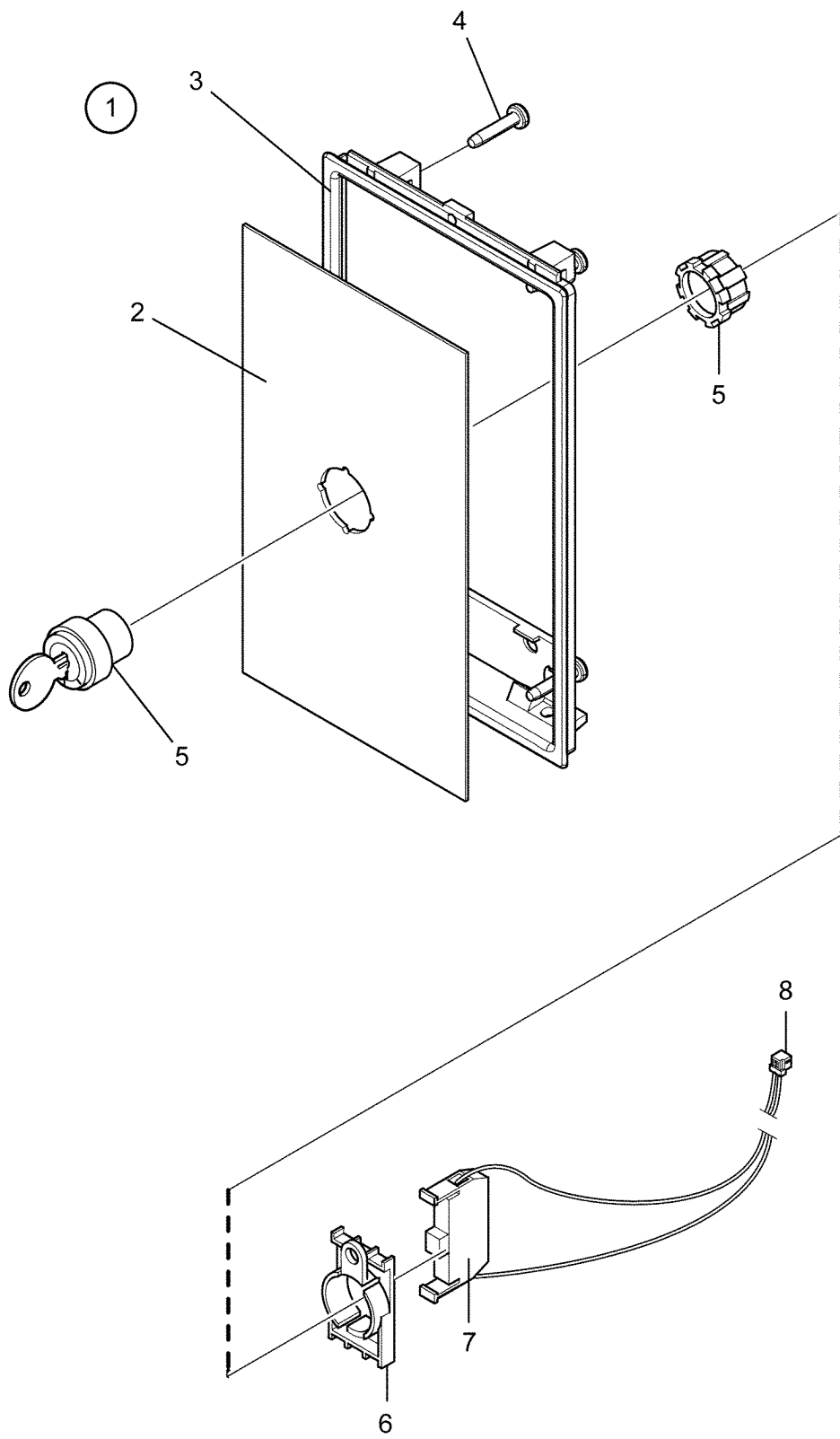

**W575H Compass,W5105H Compass,W5130H Compass,W5180H Compass,W5240H Compass,W5300H Compass**

**Key switch**

Illustration Issue Month Year  
Illustration Utgåva Månad År

**Nyckelbrytare**

**500316 1 4 2013**

Item Pos.	Qua. Ant.	Art.No Art.nr	Description	Benämning	Info Info	Notes Anmärkning
<b>1</b>	1	<b>472 9955-07</b>	Cover plates	Täckplåtar		Kit compl.
<b>2</b>	1		•Cover plate	•Täckplåt		
<b>3</b>	1		•Frame	•Ram		
<b>4</b>	4		•Screw	•Skruv		
<b>5</b>	1	<b>471 9628-85</b>	Key switch	Nyckelbrytare		
<b>6</b>	1	<b>471 9628-75</b>	Bracket	Hållare		
<b>7</b>	1	<b>471 9628-71</b>	Socket	Kontaktblock		NO Green
<b>8</b>	1	<b>413 3272-21</b>	Cable set	Ledningssats		

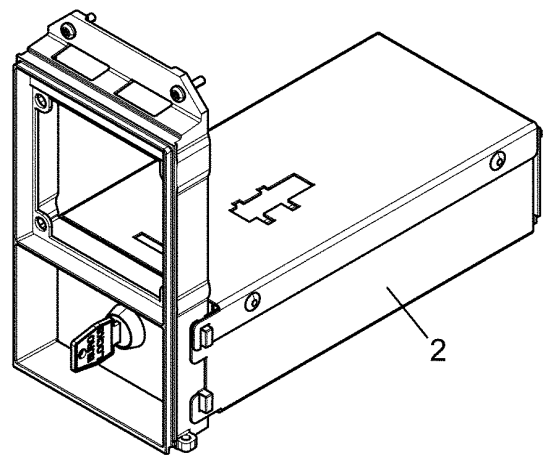
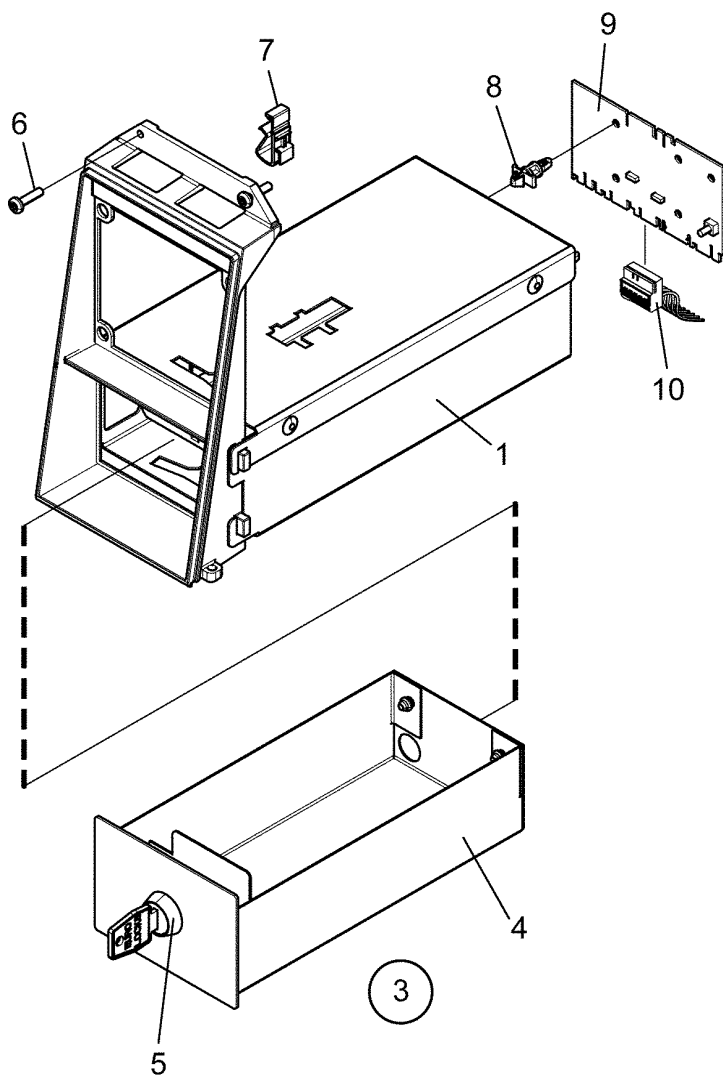

**W575H Compass,W5105H Compass,W5130H Compass,W5180H Compass,W5240H Compass,W5300H Compass**

**Coinbox housing (for coinbox height 70mm)**

Illustration Issue Month Year  
Illustration Utgåva Månad År

**Mynthus (för myntlåda höjd 70mm)**

**500452 1 4 2013**

Item Pos.	Qua. Ant.	Art.No Art.nr	Description	Benämning	Info Info	Notes Anmärkning
1	1	472 9955-02	Coinbox housing	Mynthus		Slanted frame
2	1	472 9955-04	Coinbox housing	Mynthus		Straight frame
3	1	432 2233-02	Coin box	Myntlåda		Complete Random key
4	1	432 2232-02	•Coin box	•Myntlåda		
5	1	472 9919-30	•Lock	•Lås		Random key
	1	472 9919-31	Lock	Lås		Key 46080
	1	472 9919-32	Lock	Lås		Key 46199
	1	472 9919-33	Lock	Lås		Key 46819
6	2	471 8341-15	Screw	Skruv		MRT 4X16
7	2	432 6320-01	Clamp	Klamma		
8	4	471 7960-02	Support	Stöd		
9	1	438 8775-09	Printed circuit board	Kretskort		
10	1	413 3276-01	Cable set	Ledningssats		

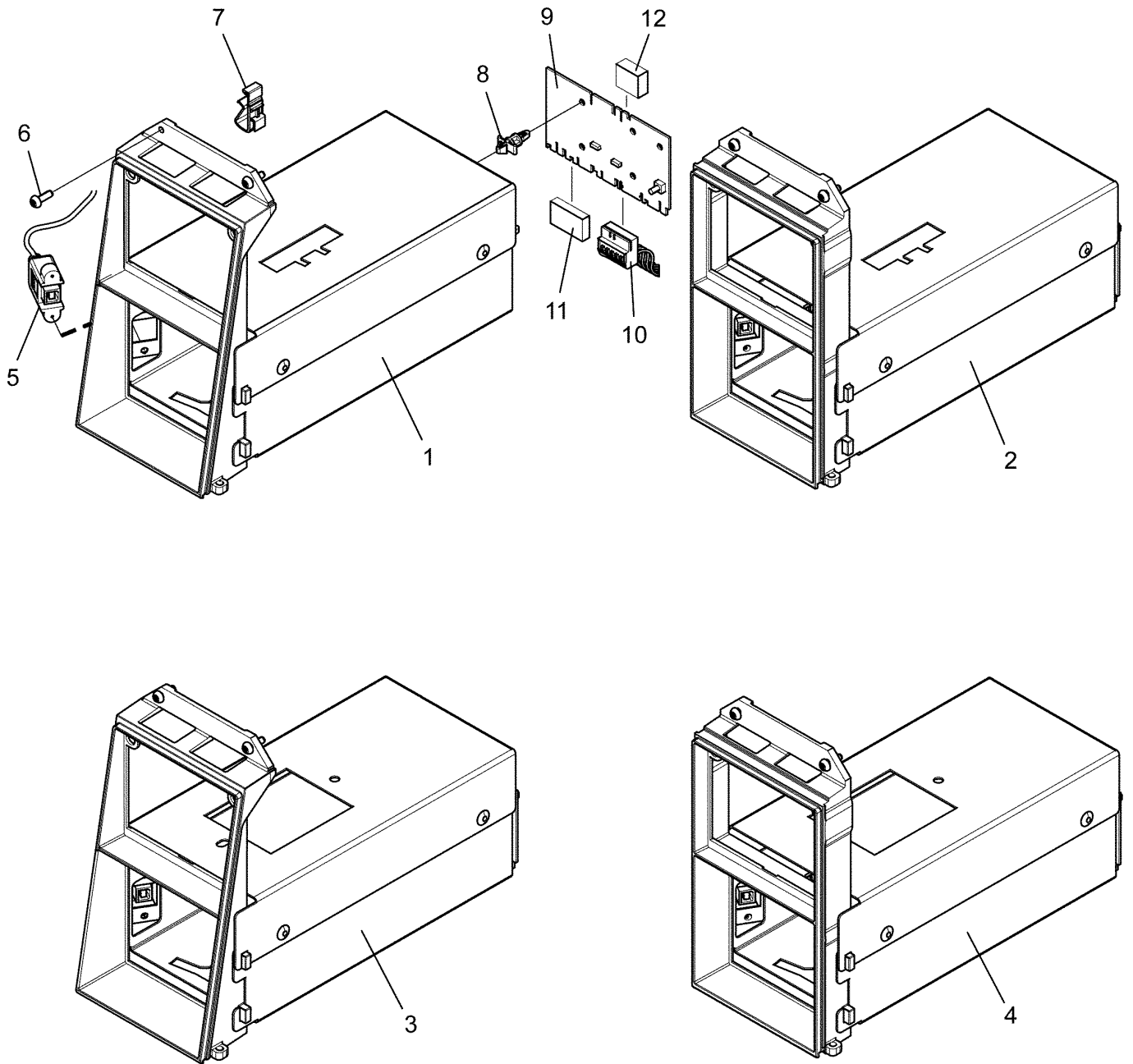



**W575H Compass,W5105H Compass,W5130H Compass,W5180H Compass,W5240H Compass,W5300H Compass**

**Coinbox housing (for coinbox height 90mm)**

Illustration Issue Month Year  
Illustration Utgåva Månad År

**Mynthus (för myntlåda höjd 90mm)**

**500453 1 4 2013**

Item Pos.	Qua. Ant.	Art.No Art.nr	Description	Benämning	Info Info	Notes Anmärkning
1	1	472 9955-01	Coinbox housing	Mynthus		Slanted frame
2	1	472 9955-03	Coinbox housing	Mynthus		Straight frame
3	1	472 9955-05	Coinbox housing	Mynthus		Slanted frame
4	1	472 9955-06	Coinbox housing	Mynthus		Straight frame
5	1	413 2936-01	Cable	Kabel		USB
6	2	471 8376-01	Screw	Skruv		M4X12
	1	471 8376-99	Tool	Verktyg		Tool for 471837601
7	2	432 6320-01	Clamp	Klamma		
8	4	471 7960-02	Support	Stöd		
9	1	438 8775-09	Printed circuit board	Kretskort		
10	1	413 3276-01	Cable set	Ledningssats		
11	1	438 8701-02	Frame	Ram		3-pole
	1	438 8701-01	Multistik	Kantanslutning		3-pole
12	1	438 8701-04	Frame	Ram		2-pole
	1	438 8701-03	Multistik	Kantanslutning		2-pole

1

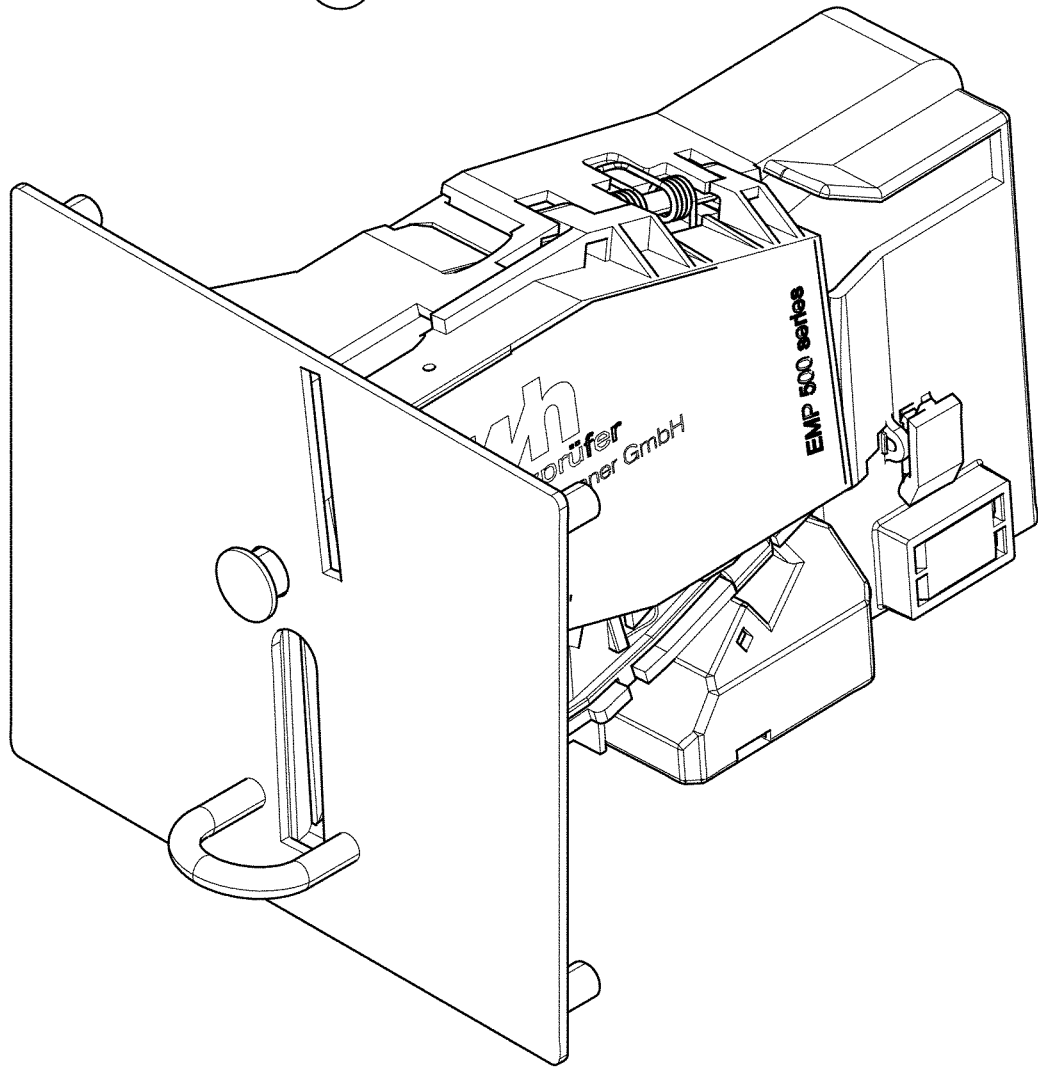

**W575H Compass,W5105H Compass,W5130H Compass,W5180H Compass,W5240H Compass,W5300H Compass**

**Electronic coin meter**

Illustration Issue Month Year  
Illustration Utgåva Månad År

**Elektronisk myntmätare**

**500199 3 6 2014**

Item Pos.	Qua. Ant.	Art.No Art.nr	Description	Benämning	Info Info	Notes Anmärkning
<b>1</b>	1	<b>438 8938-01</b>	Coin meter	Myntmätare		JPY+KRW
	1	<b>438 8938-02</b>	Coin meter	Myntmätare		NZD+AUD
	1	<b>438 8938-03</b>	Coin meter	Myntmätare		EUR+DKK+NOK
	1	<b>438 8938-04</b>	Coin meter	Myntmätare		EUR+SEK
	1	<b>438 8938-05</b>	Coin meter	Myntmätare		HKD+TWD
	1	<b>438 8938-06</b>	Coin meter	Myntmätare		MOP+MYR+SGD
	1	<b>438 8938-07</b>	Coin meter	Myntmätare		CHF+CZK+LTL
	1	<b>438 8938-08</b>	Coin meter	Myntmätare		AED+ZAR+ILS
	1	<b>438 8938-09</b>	Coin meter	Myntmätare		GBP+EUR
	1	<b>438 8938-10</b>	Coin meter	Myntmätare		PLN+EUR
	1	<b>438 8938-11</b>	Coin meter	Myntmätare		EUR+Tokens
	1	<b>438 8938-12</b>	Coin meter	Myntmätare		CNY
	1	<b>438 8938-13</b>	Coin meter	Myntmätare		HUF

1

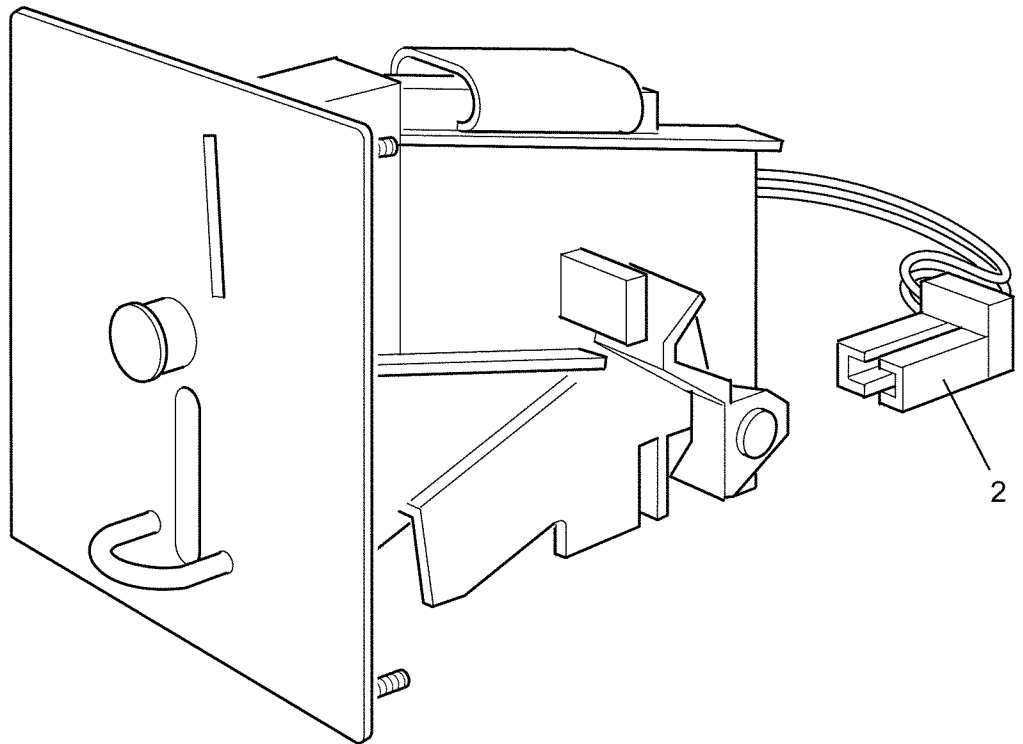

**W575H Compass,W5105H Compass,W5130H Compass,W5180H Compass,W5240H Compass,W5300H Compass**

**Coin meter**

Illustration Issue Month Year  
Illustration Utgåva Månad År

**Myntmätare**

**500201 5 7 2013**

Item Pos.	Qua. Ant.	Art.No Art.nr	Description	Benämning	Info Info	Notes Anmärkning
<b>1</b>	1	<b>438 8931-59</b>	Coin meter	Myntmätare		TOKEN 25,7x1,6
	1	<b>438 8931-60</b>	Coin meter	Myntmätare		TOKEN 26,0x2,1
	1	<b>438 8931-75</b>	Coin meter	Myntmätare		TOKEN 22,0x1,6
	1	<b>438 8931-76</b>	Coin meter	Myntmätare		TOKEN 25,0x2,0
	1	<b>438 8931-78</b>	Coin meter	Myntmätare		TOKEN 23,5x1,7
	1	<b>438 8931-79</b>	Coin meter	Myntmätare		TOKEN 25,8x1,7
	1	<b>438 8931-81</b>	Coin meter	Myntmätare		TOKEN 27,4x1,6
	1	<b>438 8931-82</b>	Coin meter	Myntmätare		TOKEN 25,0x1,8
	1	<b>438 8931-85</b>	Coin meter	Myntmätare		TOKEN 22,5x1,5
	1	<b>438 8931-86</b>	Coin meter	Myntmätare		TOKEN 27,0x1,6
	1	<b>438 8931-87</b>	Coin meter	Myntmätare		TOKEN 24,3x1,5
	1	<b>438 8931-88</b>	Coin meter	Myntmätare		TOKEN 23,7x1,6
	1	<b>438 8931-89</b>	Coin meter	Myntmätare		TOKEN 19,0x1,0
	1	<b>438 8931-90</b>	Coin meter	Myntmätare		TOKEN 19,0x1,5
	1	<b>438 8931-91</b>	Coin meter	Myntmätare		TOKEN 22,35x1,6
<b>2</b>	Rq	<b>438 8932-04</b>	Coin meter	Myntmätare		2 Coins, 0,5+1 EUR
		<b>438 8924-99</b>	•Sensor	•Sensor		

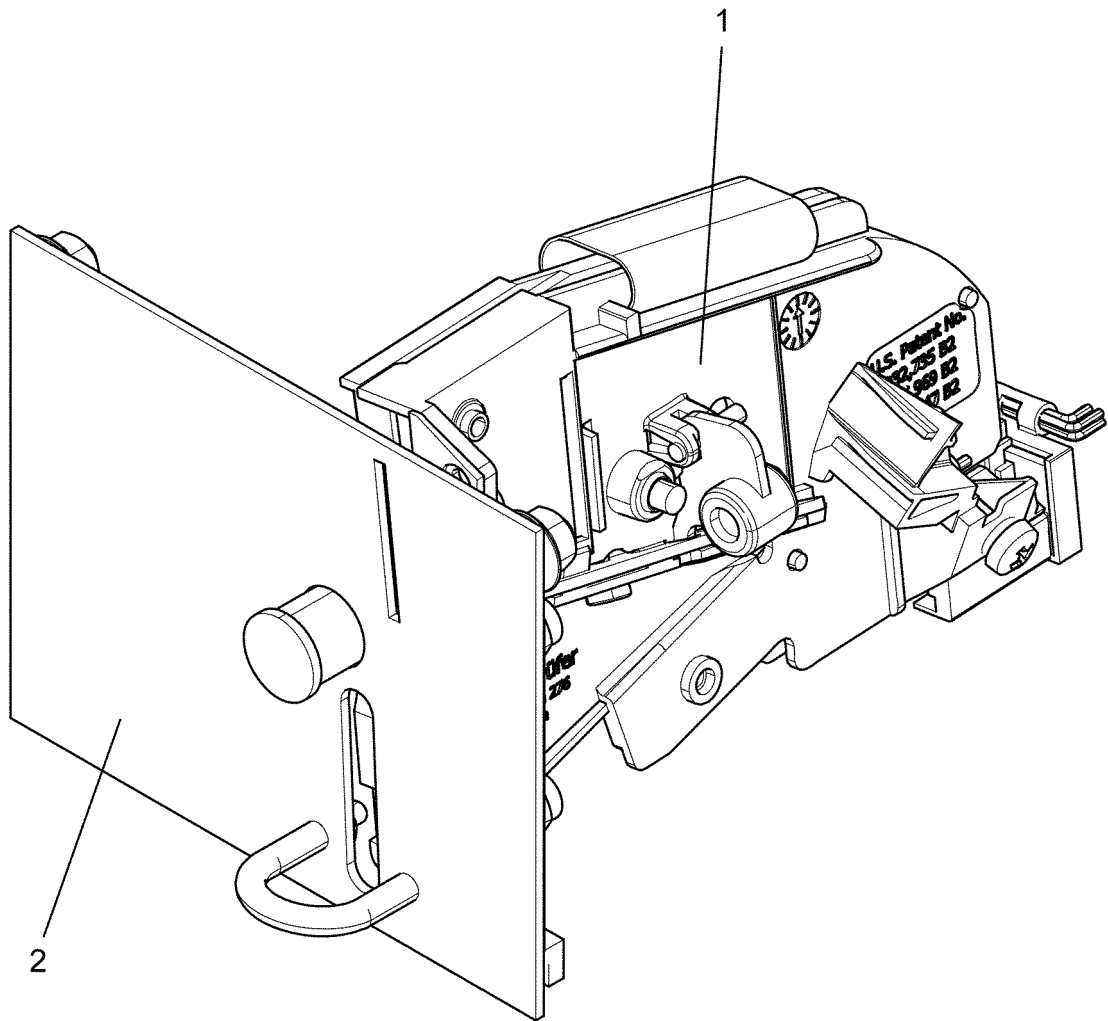

**W575H Compass,W5105H Compass,W5130H Compass,W5180H Compass,W5240H Compass,W5300H Compass**

**Coin meter (for coinbox height 90mm)**

Illustration Issue Month Year  
Illustration Utgåva Månad År

**Myntmätare (för myntlåda höjd 90mm)**

**500446 2 5 2014**

Item Pos.	Qua. Ant.	Art.No Art.nr	Description	Benämning	Info Info	Notes Anmärkning
<b>1</b>	1	<b>438 8921-10</b>	Coin meter	Myntmätare		0,25 USD
<b>2</b>	1	<b>438 8921-01</b>	Front panel	Frontplåt		0,25 USD

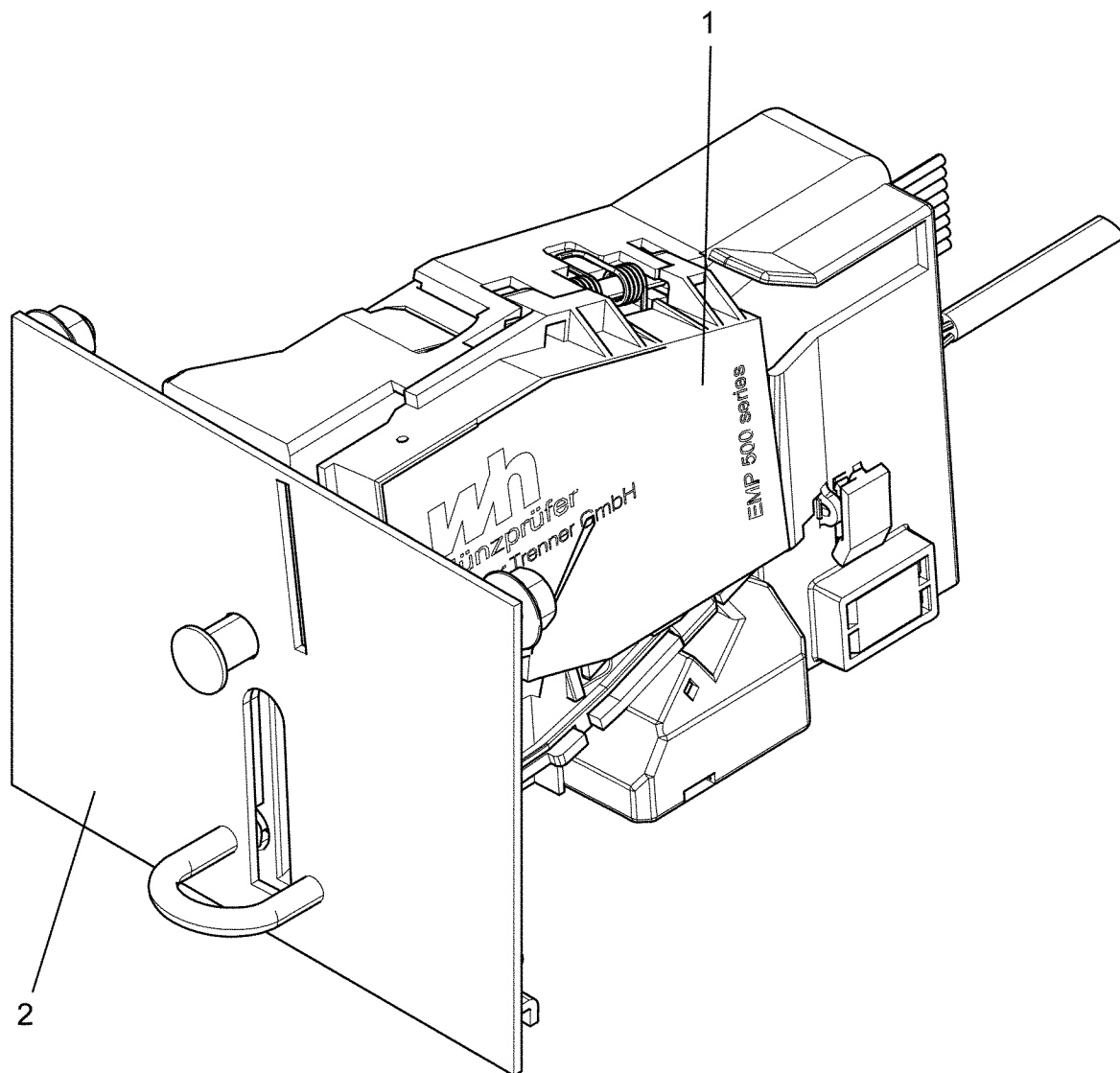

500544\_01



**W575H Compass,W5105H Compass,W5130H Compass,W5180H Compass,W5240H Compass,W5300H Compass**

**Electronic coin meter (for coinbox height 90mm)**

Illustration Issue Month Year  
Illustration Utgåva Månad År

**Elektronisk myntmätare (för myntlåda höjd 90mm)**

**500544 1 6 2014**

Item Pos.	Qua. Ant.	Art.No Art.nr	Description	Benämning	Info Info	Notes Anmärkning
<b>1</b>	1	<b>438 8935-01</b>	Coin meter	Myntmätare		JPY+KRW
	1	<b>438 8935-50</b>	Coin meter	Myntmätare		CAD+USD
<b>2</b>	1	<b>438 8934-01</b>	Front panel	Frontplåt		JPY+KRW
	1	<b>438 8934-50</b>	Front panel	Frontplåt		CAD+USD

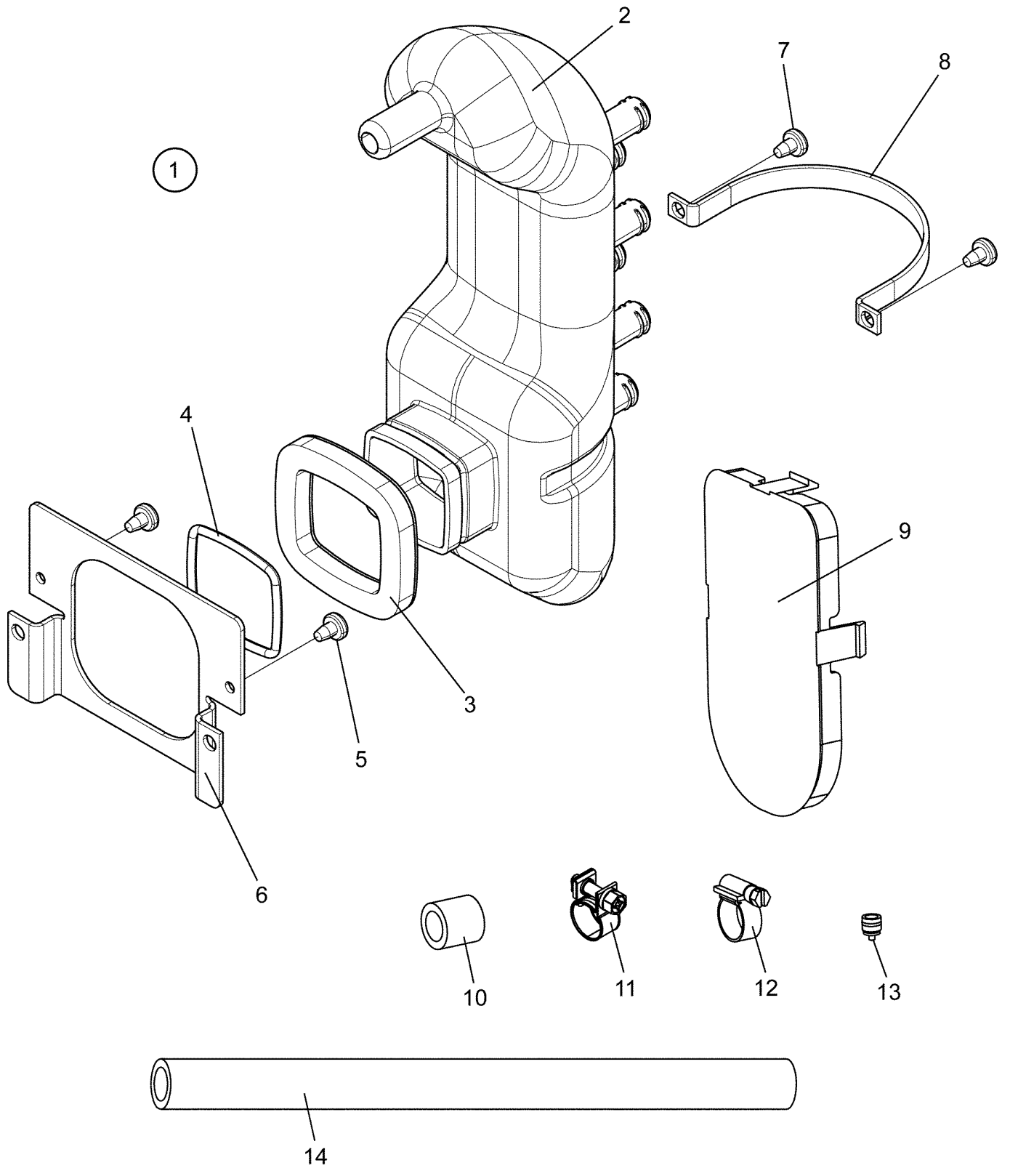

**W575H Compass,W5105H Compass,W5130H Compass,W5180H Compass,W5240H Compass,W5300H Compass**

**Liquid detergent USA**

Illustration Issue Month Year  
Illustration Utgåva Månad År

**Flytande tvättmedel USA**

**500470 2 11 2013**

Item Pos.	Qua. Ant.	Art.No Art.nr	Description	Benämning	Info Info	Notes Anmärkning
1	1	472 9958-01	Manifold	Grenrör		Complete
2	1	432 2323-01	•Manifold	•Grenrör		
3	1	438 8174-01	•Gasket	•Packning		
4	1	471 8780-91	•O-ring	•O-ring		
5	2	471 8342-13	•Screw	•Skruv		MRT-TT 4X10
6	1	432 2325-01	•Bracket	•Fäste		
7	2	471 8342-11	•Screw	•Skruv		MRT-TT 4X6
8	1	432 2324-01	•Clamp	•Klämma		
9	1	432 2409-01	•Cover	•Kåpa		
10	1	471 9037-73	•Sleeve	•Hylsa		
11	6	471 7851-10	•Hose clamp	•Slangklämma		
12	3	736 2816-51	•Hose clamp	•Slangklämma		Ø13-19
13	1	471 8234-96	•Restrictor	•Strypbricka		
14	1	438 8110-15	•Hose	•Slang		L=675



Numerical index/Nummerregister

Art.No/Art.nr	Page/Sida	Art.No/Art.nr	Page/Sida	Art.No/Art.nr	Page/Sida	Art.No/Art.nr	Page/Sida
413 1221-01	49	413 2965-02	21	413 3276-08	47	432 1438-02	23
413 1226-01	61	413 2965-03	17	413 3276-09	47	432 1453-01	7
413 2201-21	25	413 2965-03	21	413 3276-11	47	432 1453-01	9
413 2201-22	25	413 2965-04	17	413 3704-12	15	432 1453-01	11
413 2201-23	25	413 2965-04	21	413 3704-12	19	432 1453-01	13
413 2201-24	25	413 2965-05	17	413 3704-12	23	432 1453-01	17
413 2621-01	51	413 2965-11	11	413 4312-02	37	432 1453-01	21
413 2621-02	51	413 2965-12	11	413 5004-01	63	432 1454-01	43
413 2623-01	51	413 2965-13	11	413 5006-01	25	432 1455-01	43
413 2623-02	51	413 2965-22	13	413 5008-01	25	432 1458-01	7
413 2624-01	53	413 2965-23	13	413 5068-01	11	432 1458-01	9
413 2624-02	53	413 2965-24	11	413 5068-01	13	432 1458-01	11
413 2625-02	53	413 2965-24	13	413 9701-31	43	432 1458-01	13
413 2625-04	53	413 2965-25	13	432 0641-01	43	432 1458-01	17
413 2627-01	53	413 3082-05	61	432 1206-01	7	432 1459-01	9
413 2627-02	53	413 3082-21	73	432 1211-02	7	432 1459-02	7
413 2628-01	53	413 3082-29	73	432 1212-03	7	432 1468-01	17
413 2628-02	53	413 3082-30	73	432 1220-01	61	432 1468-01	21
413 2631-16	51	413 3082-35	59	432 1229-01	43	432 1470-01	11
413 2631-18	51	413 3084-02	61	432 1256-01	9	432 1470-01	13
413 2631-19	51	413 3084-10	47	432 1257-01	7	432 1473-01	43
413 2631-21	51	413 3084-21	47	432 1261-01	9	432 1500-11	31
413 2631-22	53	413 3084-22	47	432 1262-02	9	432 1500-15	31
413 2631-24	53	413 3084-23	47	432 1264-01	9	432 1501-01	31
413 2631-30	53	413 3084-24	47	432 1265-01	9	432 1501-05	31
413 2631-31	53	413 3084-25	61	432 1295-01	11	432 1502-01	31
413 2631-38	53	413 3086-07	69	432 1295-01	13	432 1502-03	31
413 2631-39	53	413 3086-08	69	432 1295-01	17	432 1502-05	31
413 2631-46	53	413 3086-08	71	432 1295-01	21	432 1503-01	31
413 2631-47	53	413 3086-10	71	432 1306-01	11	432 1503-05	31
413 2902-02	81	413 3088-07	67	432 1307-01	11	432 1504-01	31
413 2902-04	81	413 3088-07	71	432 1311-01	11	432 1504-05	31
413 2902-06	81	413 3088-07	73	432 1312-02	11	432 1504-41	33
413 2902-08	81	413 3088-08	75	432 1335-01	17	432 1504-42	33
413 2902-10	81	413 3088-08	77	432 1335-01	21	432 1540-01	33
413 2902-12	81	413 3088-10	71	432 1336-01	13	432 1541-01	33
413 2903-02	83	413 3088-10	75	432 1356-01	13	432 1542-01	33
413 2903-04	83	413 3088-10	77	432 1357-01	13	432 1543-01	33
413 2905-02	59	413 3182-02	59	432 1360-01	13	432 1544-01	33
413 2915-01	25	413 3182-09	75	432 1361-01	13	432 1545-01	33
413 2915-01	29	413 3182-09	77	432 1362-01	13	432 1546-01	33
413 2915-02	25	413 3182-10	75	432 1399-02	21	432 1547-01	33
413 2915-02	59	413 3182-10	77	432 1406-01	17	432 1548-01	33
413 2918-01	47	413 3182-11	77	432 1406-01	21	432 1549-01	33
413 2918-01	61	413 3182-14	77	432 1406-02	17	432 1550-01	33
413 2918-02	47	413 3182-15	75	432 1406-02	21	432 1551-01	33
413 2918-02	61	413 3182-15	77	432 1407-01	17	432 1552-01	33
413 2918-03	47	413 3182-16	75	432 1407-01	21	432 1553-01	33
413 2918-03	61	413 3182-16	77	432 1407-02	17	432 1554-01	33
413 2918-04	47	413 3182-17	77	432 1407-02	21	432 1560-01	33
413 2918-04	61	413 3184-02	63	432 1411-01	17	432 1561-01	33
413 2918-05	47	413 3184-05	63	432 1412-01	17	432 1562-01	33
413 2918-05	61	413 3272-06	7	432 1413-01	21	432 1563-01	33
413 2918-06	47	413 3272-09	9	432 1414-01	21	432 1564-01	33
413 2918-06	61	413 3272-15	17	432 1418-01	11	432 1565-01	33
413 2918-07	47	413 3272-15	21	432 1419-01	11	432 1566-01	33
413 2918-08	47	413 3272-17	11	432 1420-01	13	432 1567-01	35
413 2918-09	47	413 3272-19	91	432 1421-01	13	432 1568-01	35
413 2936-01	51	413 3272-21	93	432 1421-01	17	432 1569-01	35
413 2936-01	53	413 3272-22	13	432 1421-01	21	432 1570-11	31
413 2936-01	97	413 3274-01	59	432 1426-01	17	432 1570-12	31
413 2946-01	61	413 3274-20	57	432 1426-01	21	432 1570-13	31
413 2965-01	13	413 3274-32	61	432 1437-01	21	432 1571-01	31
413 2965-01	17	413 3276-01	95	432 1438-01	11	432 1571-02	31
413 2965-01	21	413 3276-01	97	432 1438-01	15	432 1571-03	31
413 2965-02	17	413 3276-02	47	432 1438-01	19	432 1572-01	31

Numerical index/Nummerregister

Art.No/Art.nr	Page/Sida	Art.No/Art.nr	Page/Sida	Art.No/Art.nr	Page/Sida	Art.No/Art.nr	Page/Sida
432 1572-02	31	432 1857-01	37	432 2065-01	27	432 2362-01	51
432 1572-03	31	432 1857-02	37	432 2066-01	27	432 2366-01	53
432 1573-01	31	432 1858-01	37	432 2067-01	27	432 2367-01	53
432 1573-02	31	432 1858-02	37	432 2068-01	27	432 2368-01	53
432 1573-03	31	432 1870-01	37	432 2069-01	27	432 2372-01	27
432 1574-01	31	432 1871-01	37	432 2120-01	25	432 2404-51	87
432 1574-02	31	432 1872-01	37	432 2121-02	29	432 2405-02	87
432 1574-03	31	432 1873-01	37	432 2121-03	29	432 2406-02	87
432 1574-21	31	432 1874-01	37	432 2121-04	29	432 2407-01	87
432 1574-22	31	432 1885-03	37	432 2122-01	25	432 2409-01	87
432 1574-23	31	432 1885-11	37	432 2130-01	25	432 2409-01	107
432 1589-01	33	432 1886-02	37	432 2130-03	25	432 2412-01	87
432 1605-21	31	432 1886-11	37	432 2131-01	27	432 2413-01	87
432 1605-25	31	432 1887-03	37	432 2131-02	27	432 2501-01	79
432 1605-26	31	432 1887-04	37	432 2131-03	29	432 2502-01	63
432 1606-01	31	432 1887-11	37	432 2131-04	29	432 2502-01	79
432 1606-02	31	432 1887-12	37	432 2135-01	27	432 2505-01	79
432 1606-06	31	432 1888-04	37	432 2135-02	27	432 2506-01	63
432 1607-01	31	432 1888-05	37	432 2137-01	29	432 2507-01	63
432 1607-02	31	432 1888-11	37	432 2139-01	29	432 2508-01	63
432 1607-04	31	432 1888-12	37	432 2147-01	29	432 2508-03	63
432 1607-05	31	432 1950-02	37	432 2154-01	59	432 2508-04	63
432 1607-07	31	432 1951-01	37	432 2163-11	27	432 2511-01	63
432 1608-01	31	432 1961-01	37	432 2163-13	27	432 2515-01	63
432 1608-03	31	432 1962-01	37	432 2164-11	25	432 2516-02	63
432 1608-07	31	432 1982-01	41	432 2164-12	25	432 2516-04	81
432 1609-01	31	432 2002-01	27	432 2180-01	25	432 2516-05	81
432 1609-04	31	432 2003-01	27	432 2183-01	89	432 2517-01	81
432 1609-07	31	432 2004-01	27	432 2199-01	59	432 2518-01	81
432 1609-51	31	432 2032-03	27	432 2199-03	59	432 2518-03	81
432 1609-52	31	432 2032-10	27	432 2199-05	59	432 2518-04	81
432 1609-53	31	432 2033-10	27	432 2202-01	89	432 2520-01	63
432 1630-01	85	432 2033-11	27	432 2202-02	89	432 2520-02	63
432 1631-01	85	432 2033-31	27	432 2207-33	27	432 2524-01	81
432 1649-01	11	432 2033-32	27	432 2207-40	27	432 2524-01	83
432 1649-01	13	432 2034-03	27	432 2214-01	59	432 2524-02	81
432 1649-01	17	432 2034-10	27	432 2215-01	25	432 2524-02	83
432 1649-01	21	432 2035-10	27	432 2215-01	29	432 2528-03	63
432 1650-01	11	432 2035-11	27	432 2232-02	95	432 2528-05	63
432 1651-01	13	432 2035-31	27	432 2233-02	95	432 2530-02	81
432 1652-01	17	432 2035-32	27	432 2256-01	59	432 2531-01	81
432 1653-01	7	432 2036-03	27	432 2257-01	59	432 2532-01	83
432 1653-01	9	432 2036-10	27	432 2258-01	59	432 2533-01	83
432 1653-01	11	432 2037-10	27	432 2259-01	29	432 2534-01	81
432 1653-01	13	432 2037-11	27	432 2270-02	39	432 2536-01	81
432 1653-01	17	432 2037-31	27	432 2273-01	25	432 2537-01	81
432 1653-01	21	432 2037-32	27	432 2273-01	27	432 2538-01	83
432 1654-01	7	432 2038-03	29	432 2280-65	25	432 2548-01	81
432 1654-01	9	432 2038-10	29	432 2280-66	25	432 2653-10	51
432 1654-01	11	432 2040-03	29	432 2281-65	25	432 2653-10	53
432 1654-01	13	432 2040-10	29	432 2281-66	25	432 2653-11	51
432 1654-01	17	432 2050-01	27	432 2305-01	65	432 2653-11	53
432 1654-01	21	432 2050-02	27	432 2306-01	65	432 2653-12	51
432 1655-01	33	432 2051-01	27	432 2308-01	65	432 2653-12	53
432 1656-01	33	432 2051-02	27	432 2312-01	65	432 2653-14	51
432 1673-01	85	432 2052-01	27	432 2314-01	65	432 2653-14	53
432 1840-02	37	432 2052-02	27	432 2320-01	65	432 2653-15	51
432 1840-03	37	432 2057-03	25	432 2323-01	107	432 2653-15	53
432 1841-02	37	432 2057-10	25	432 2324-01	107	432 2653-30	51
432 1841-04	37	432 2058-03	25	432 2325-01	107	432 2653-30	53
432 1842-02	37	432 2058-10	25	432 2351-01	25	432 2653-31	51
432 1842-03	37	432 2059-05	27	432 2352-01	27	432 2653-31	53
432 1843-02	37	432 2059-06	27	432 2354-01	25	432 2653-80	51
432 1843-04	37	432 2059-10	27	432 2355-01	27	432 2653-80	53
432 1855-01	37	432 2059-11	27	432 2356-01	27	432 2905-27	41
432 1856-01	37	432 2064-01	27	432 2361-01	51	432 2905-29	41

Numerical index/Nummerregister

Art.No/Art.nr	Page/Sida	Art.No/Art.nr	Page/Sida	Art.No/Art.nr	Page/Sida	Art.No/Art.nr	Page/Sida
432 2905-31	41	438 0056-04	65	438 8932-04	101	471 2436-10	25
432 2905-33	41	438 0083-01	63	438 8934-01	105	471 2436-10	29
432 2905-35	41	438 4062-01	37	438 8934-50	105	471 2437-15	27
432 2950-02	7	438 5022-01	83	438 8935-01	105	471 2442-41	55
432 2950-02	9	438 5040-01	63	438 8935-50	105	471 2442-42	63
432 2953-10	7	438 5109-02	25	438 8938-01	99	471 2464-18	63
432 2953-10	9	438 5124-05	43	438 8938-02	99	471 2937-01	85
432 2954-03	59	438 7507-01	25	438 8938-03	99	471 4391-02	83
432 2954-13	59	438 7509-01	7	438 8938-04	99	471 4672-67	25
432 2954-14	59	438 7509-02	9	438 8938-05	99	471 4673-93	61
432 2954-26	83	438 7510-01	9	438 8938-06	99	471 4835-01	63
432 2961-01	47	438 7950-01	61	438 8938-07	99	471 6858-82	83
432 2977-01	11	438 7950-02	61	438 8938-08	99	471 6858-83	83
432 2977-01	13	438 8102-06	63	438 8938-09	99	471 7565-21	25
432 2977-01	17	438 8110-15	107	438 8938-10	99	471 7565-21	29
432 2977-01	21	438 8120-01	63	438 8938-11	99	471 7705-02	43
432 2982-10	81	438 8120-02	63	438 8938-12	99	471 7705-03	43
432 2983-01	45	438 8120-03	63	438 8938-13	99	471 7711-07	43
432 2983-02	45	438 8155-01	33	438 9515-01	83	471 7711-12	43
432 2983-03	59	438 8155-02	33	438 9561-01	41	471 7711-13	43
432 2983-04	59	438 8155-03	33	438 9562-01	11	471 7807-02	7
432 2984-01	59	438 8155-04	33	438 9563-01	13	471 7807-02	9
432 2985-01	7	438 8155-05	33	438 9563-01	17	471 7807-02	11
432 2985-01	9	438 8156-01	11	438 9563-01	21	471 7807-02	13
432 2985-01	11	438 8156-01	13	438 9565-01	7	471 7807-02	17
432 2985-01	13	438 8156-01	17	438 9565-01	9	471 7807-02	21
432 2985-01	17	438 8156-03	21	438 9566-01	7	471 7818-01	79
432 2985-01	21	438 8158-01	43	438 9566-01	9	471 7826-10	25
432 2987-01	89	438 8158-02	43	438 9569-01	7	471 7826-10	29
432 2990-01	43	438 8160-01	7	438 9569-01	9	471 7851-10	107
432 2990-02	43	438 8160-01	9	438 9569-01	11	471 7859-16	59
432 2991-01	43	438 8172-01	43	438 9569-01	13	471 7864-01	25
432 2998-01	7	438 8174-01	107	438 9569-01	17	471 7871-04	65
432 2998-01	9	438 8270-01	83	438 9569-01	21	471 7871-04	79
432 3058-04	85	438 8270-02	83	438 9572-01	11	471 7871-07	63
432 3092-86	59	438 8701-01	59	438 9573-01	13	471 7871-07	81
432 3106-01	59	438 8701-01	97	438 9573-01	17	471 7871-07	83
432 3604-01	61	438 8701-02	97	438 9573-01	21	471 7871-08	65
432 3604-02	61	438 8701-03	59	438 9636-22	59	471 7887-01	63
432 6318-01	25	438 8701-03	97	438 9636-23	59	471 7958-02	61
432 6318-01	29	438 8701-04	97	438 9636-24	59	471 7960-02	61
432 6320-01	59	438 8720-01	59	438 9636-92	59	471 7960-02	95
432 6320-01	95	438 8720-02	59	438 9636-93	59	471 7960-02	97
432 6320-01	97	438 8720-03	59	438 9636-94	59	471 7977-01	65
432 6323-01	61	438 8774-02	47	438 9678-01	59	471 7977-03	61
432 6346-06	55	438 8775-09	95	438 9678-02	59	471 7977-04	61
432 6353-02	55	438 8775-09	97	438 9678-03	59	471 7977-04	65
432 6355-02	57	438 8797-02	61	438 9678-04	59	471 7980-01	29
432 6356-01	57	438 8921-01	103	438 9678-11	59	471 7984-01	61
432 6372-01	57	438 8921-10	103	438 9678-12	59	471 8116-17*	83
432 6373-01	57	438 8924-99	101	438 9678-13	59	471 8126-25	85
432 6805-07	59	438 8931-59	101	438 9678-14	59	471 8126-26	85
432 6809-01	55	438 8931-60	101	438 9702-71	43	471 8126-27	85
432 6810-02	57	438 8931-75	101	438 9703-21	43	471 8126-28	85
432 6820-02	55	438 8931-76	101	438 9705-21	43	471 8126-29	85
432 6903-02	61	438 8931-78	101	438 9705-61	43	471 8126-38	85
432 6903-03	59	438 8931-79	101	438 9705-71	43	471 8128-54	63
432 6930-03	59	438 8931-81	101	438 9799-01	47	471 8128-59	63
432 6933-03	61	438 8931-82	101	438 9799-02	43	471 8128-60	63
432 6937-01	49	438 8931-85	101	438 9799-03	43	471 8128-62	63
438 0051-01	79	438 8931-86	101	438 9799-12	47	471 8128-66	63
438 0052-01	79	438 8931-87	101	471 2265-69	25	471 8128-68	63
438 0053-01	79	438 8931-88	101	471 2265-69	29	471 8128-73	63
438 0054-01	79	438 8931-89	101	471 2265-69	55	471 8139-01	63
438 0055-01	79	438 8931-90	101	471 2265-69	63	471 8139-11	63
438 0056-03	65	438 8931-91	101	471 2409-89	65	471 8139-16	63

Numerical index/Nummerregister

Art.No/Art.nr	Page/Sida	Art.No/Art.nr	Page/Sida	Art.No/Art.nr	Page/Sida	Art.No/Art.nr	Page/Sida
471 8175-01	65	471 8342-13	107	471 9608-01	89	472 5797-50	51
471 8180-10	11	471 8342-15	29	471 9628-32	91	472 5797-50	53
471 8180-10	13	471 8342-23	43	471 9628-71	91	472 5797-51	51
471 8180-10	17	471 8342-47	41	471 9628-71	93	472 5797-51	53
471 8180-10	23	471 8344-35	25	471 9628-75	91	472 5797-80	51
471 8195-01	79	471 8344-36	39	471 9628-75	93	472 5797-80	53
471 8196-01	25	471 8356-05	43	471 9628-85	93	472 6760-01	83
471 8199-01	65	471 8356-06	43	471 9678-94	61	472 9768-01	33
471 8210-70	75	471 8356-08	43	471 9821-99	7	472 9900-99	25
471 8210-70	77	471 8356-14	43	471 9821-99	9	472 9900-99	29
471 8210-71	75	471 8376-01	97	471 9822-99	11	472 9904-98	7
471 8210-71	77	471 8376-99	97	471 9822-99	15	472 9904-98	9
471 8210-78	75	471 8404-02	37	471 9822-99	19	472 9904-98	11
471 8210-78	77	471 8404-03	79	471 9822-99	23	472 9904-98	13
471 8210-79	75	471 8413-01	7	471 9825-01	11	472 9904-98	17
471 8210-79	77	471 8413-01	9	471 9825-02	11	472 9904-98	21
471 8215-01	81	471 8413-01	11	471 9825-03	11	472 9913-03	7
471 8215-03	81	471 8413-01	13	471 9825-04	11	472 9913-04	9
471 8234-52	73	471 8413-01	17	471 9825-11	13	472 9913-05	11
471 8234-96	107	471 8413-01	21	471 9825-12	13	472 9913-06	13
471 8236-76	69	471 8458-02	37	471 9825-13	13	472 9913-07	17
471 8236-76	71	471 8502-00	43	471 9825-21	17	472 9913-08	7
471 8236-78	69	471 8502-10	43	471 9825-21	21	472 9913-08	9
471 8236-78	71	471 8502-14	35	471 9825-22	17	472 9913-08	17
471 8236-79	69	471 8502-14	43	471 9825-22	21	472 9913-08	21
471 8236-79	71	471 8502-34	7	471 9825-23	17	472 9913-09	11
471 8240-63	67	471 8502-34	9	471 9825-23	21	472 9913-10	13
471 8240-63	73	471 8502-34	11	471 9825-24	17	472 9913-10	17
471 8240-63	75	471 8502-34	13	471 9825-24	21	472 9913-11	11
471 8240-63	77	471 8502-34	17	471 9829-01	11	472 9913-11	13
471 8240-64	71	471 8502-34	21	471 9829-02	11	472 9913-12	33
471 8240-67	71	471 8502-34	23	471 9829-04	11	472 9913-13	33
471 8240-68	71	471 8527-01	39	471 9829-11	13	472 9913-17	33
471 8240-69	73	471 8555-03	7	471 9829-12	13	472 9913-18	33
471 8240-69	75	471 8555-03	9	471 9829-13	13	472 9913-19	33
471 8240-69	77	471 8555-03	11	471 9829-21	17	472 9913-33	21
471 8243-07	63	471 8555-03	13	471 9829-21	21	472 9913-63	21
471 8243-08	63	471 8555-03	17	471 9829-22	17	472 9913-64	33
471 8243-09	63	471 8555-03	21	471 9829-22	21	472 9919-30	95
471 8243-10	63	471 8624-01	85	471 9829-23	17	472 9919-31	95
471 8279-08	85	471 8641-02	25	471 9829-23	21	472 9919-32	95
471 8322-03	43	471 8641-02	27	471 9837-01	7	472 9919-33	95
471 8323-01	33	471 8644-02	65	471 9837-04	7	472 9920-01	39
471 8328-02	33	471 8688-13	65	471 9837-05	7	472 9920-31	85
471 8328-05	7	471 8688-13	79	471 9837-06	7	472 9929-31	47
471 8328-05	9	471 8693-21	65	471 9837-07	7	472 9929-32	47
471 8328-05	11	471 8695-01	85	471 9837-08	7	472 9929-41	47
471 8328-05	13	471 8697-01	85	471 9837-11	9	472 9929-51	47
471 8328-05	17	471 8750-11	61	471 9837-12	9	472 9938-01	47
471 8328-05	21	471 8750-16	59	471 9837-13	9	472 9938-02	47
471 8328-06	7	471 8767-01	59	471 9837-14	9	472 9938-03	47
471 8328-06	9	471 8767-02	59	471 9837-15	9	472 9940-02	51
471 8328-07	7	471 8768-02	47	471 9839-01	7	472 9940-02	53
471 8328-07	9	471 8780-91	107	471 9839-11	9	472 9940-04	51
471 8328-08	11	471 8783-01	59	472 5797-10	51	472 9940-04	53
471 8328-08	17	471 8783-03	59	472 5797-10	53	472 9951-01	25
471 8328-08	21	471 8783-04	59	472 5797-12	51	472 9951-03	25
471 8328-09	13	471 8826-01	43	472 5797-12	53	472 9951-11	25
471 8328-09	17	471 8827-01	43	472 5797-13	51	472 9951-13	25
471 8328-09	21	471 8861-02	25	472 5797-13	53	472 9951-21	25
471 8328-11	13	471 8861-02	29	472 5797-30	51	472 9951-23	25
471 8340-13	51	471 8861-03	55	472 5797-30	53	472 9952-01	29
471 8340-13	53	471 8863-02	55	472 5797-35	51	472 9952-02	29
471 8341-15	95	471 9037-73	107	472 5797-35	53	472 9952-03	29
471 8342-11	107	471 9219-65	81	472 5797-40	51	472 9952-04	29
471 8342-13	45	471 9222-59	35	472 5797-40	53	472 9952-05	29



Numerical index/Nummerregister

Art.No/Art.nr	Page/Sida	Art.No/Art.nr	Page/Sida	Art.No/Art.nr	Page/Sida	Art.No/Art.nr	Page/Sida
472 9952-06	29	735 9370-01	33				
472 9952-07	29	735 9501-01	33				
472 9952-08	29	735 9630-01	33				
472 9952-10	29	736 2816-51	65				
472 9952-11	29	736 2816-51	83				
472 9952-12	29	736 2816-51	107				
472 9952-13	29	736 2825-51	63				
472 9953-01	37	736 2825-51	65				
472 9953-02	37	736 2825-51	83				
472 9953-03	37	736 2831-51	63				
472 9953-04	37	736 2837-51	63				
472 9954-01	87	736 2837-51	65				
472 9954-03	87	736 2837-51	81				
472 9955-01	97	736 2837-51	83				
472 9955-02	95	736 2840-51	63				
472 9955-03	97	736 2840-51	83				
472 9955-04	95	736 2846-51	63				
472 9955-05	97	736 2846-51	65				
472 9955-06	97	736 2846-51	81				
472 9955-07	51	736 2849-51	83				
472 9955-07	53	740 4206-00	65				
472 9955-07	91	741 5109-25	65				
472 9955-07	93	744 3113-06	85				
472 9956-01	51	877 5211-08	65				
472 9956-01	53						
472 9956-02	51						
472 9956-02	53						
472 9956-03	51						
472 9956-03	53						
472 9957-01	37						
472 9958-01	107						
490 4440-17	59						
725 2366-61	37						
725 2461-51	7						
725 2461-51	9						
725 2461-51	11						
725 2461-51	13						
725 2461-51	17						
725 2461-51	21						
725 2464-51	7						
725 2464-51	9						
725 2464-51	11						
725 2464-51	13						
725 2464-51	17						
725 2464-51	21						
725 2465-71	7						
725 2465-71	9						
725 2465-71	11						
725 2465-71	13						
725 2465-71	17						
725 2465-71	21						
732 2118-01	7						
732 2118-01	9						
732 2118-01	11						
732 2118-01	13						
732 2118-01	17						
732 2118-01	21						
732 2118-01	35						
732 2118-01	43						
732 2122-01	43						
734 1178-01	43						
735 2153-01	25						
735 3133-00	33						
735 3139-00	33						
735 3144-00	33						
735 3147-00	33						







**ELECTROLUX LAUNDRY SYSTEMS**

ELECTROLUX LAUNDRY SYSTEMS SWEDEN AB  
341 80 Ljungby, Sweden. Telephone +46 372 661 00. Telefax +46 372 133 90  
Internet: [www.electrolux-wascator.com](http://www.electrolux-wascator.com) E-mail: [els.info@electrolux.se](mailto:els.info@electrolux.se)